

# XCL-V500 (VGA size)

# XCL-X700 (XGA size)

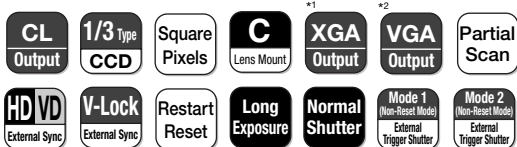

\*1: XCL-X700  
\*2: XCL-V500



## Outline

Sony's new XCL Series equipped with a digital video interface that conforms to the Camera Link™ industry standard.

These new cameras enable the capture of high-speed, high resolution images while simplifying connectivity to machine-vision systems with its standard 3M MDR 26-pin cable.

The XCL-V500 and XCL-X700 cameras feature a 1/3-type progressive scan CCD that captures high quality black and white images at a high frame rate, designed in a compact and lightweight body.

Sony's XCL Series of high-performance and feature-rich cameras is the ideal solution for today's wide range of machine vision applications.

## Features

- 1/3-type progressive scanning CCD with square pixels
- High-rate scanning
  - XCL-V500: VGA image (648 x 494 pixels) captures video at 60 fps
  - XCL-X700: XGA image (1,024 x 768 pixels) captures video at 29.2 fps
- Effective picture element
  - XCL-V500: 659(H) x 494(V)
  - XCL-X700: 1034(H) x 779(V)
- High sensitivity
  - 400 lx at F 5.6
- Camera Link standard conformity
- Compact and lightweight
- External trigger shutter: 1/4 to 1/100,000 sec.
- Synchronization signal: Internal/external (HD/VD)
- C-mount lens
- Partial scanning
- Binning function
- High shock and vibration resistance

## Accessories

- Compact camera adaptor
  - DC-700/700CE
- 12-pin camera cable (CE standard)
  - CCXC-12P02N (2 m)
  - CCXC-12P05N (5 m)
  - CCXC-12P10N (10 m)
  - CCXC-12P25N (25 m)
- Tripod adaptor
  - VCT-333I
- C-mount LENS
  - For: XCL-V500
    - VCL-08YM
    - VCL-12YM
    - VCL-16Y-M
    - VCL-25Y-M
    - VCL-50Y-M
  - For: XCL-X700
    - VCL-12YM

## Dimensions

Camera body of all models

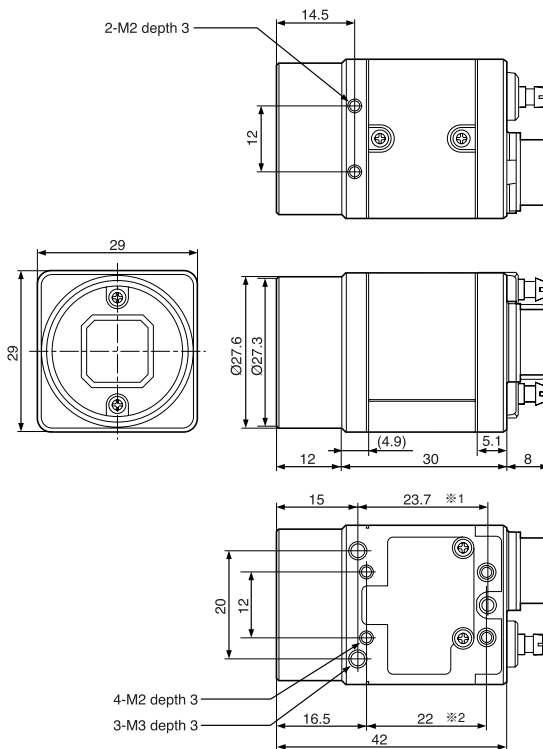

Unit: mm

\*1: for 3-M3 screw  
\*2: for 4-M2 screw

## Spectral Sensitivity Characteristics

### ●XCL-V500

(Typical Values)

Relative sensitivity

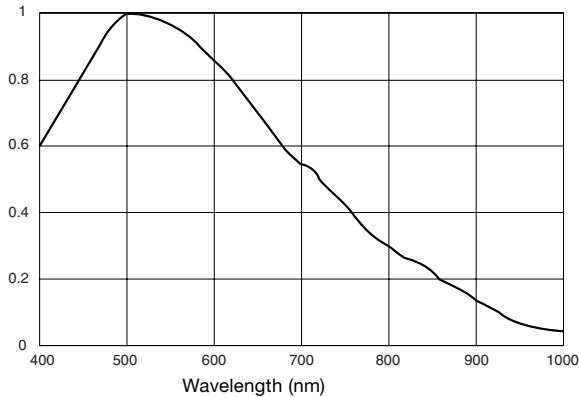

(Lens characteristics and light source characteristics excluded.)

### ●XCL-X700

(Typical Values)

Relative sensitivity

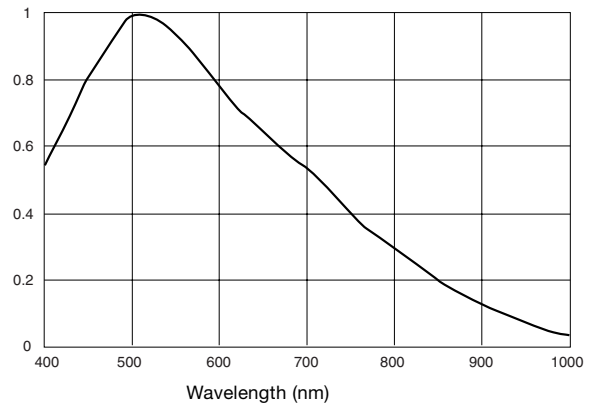

(Lens characteristics and light source characteristics excluded.)

## Specifications

	XCL-V500	XCL-X700
Image device	1/3 type progressive scan IT CCD	
Effective picture elements (H x V)	659 (H) x 494 (V)	1034(H) x 779(V)
Effective lines (H x V)	648 (H) x 494 (V)	1024 (H) x 768 (V)
Output image size	VGA	XGA
Cell size	7.4 (H) x 7.4 (V) μm	4.65 (H) x 4.65 (V) μm
Lens mount	C-mount	
Synchronization	Internal/External (automatically switched according to input signal)	
External sync signal I/O	HD/VD (HD/VD level: 2 to 5 Vp-p)	
External sync allowable frequency	±1% (horizontal sync frequency)	
H Jitter	Less than 20nsec (Internal clock)	
Video output	LVDS 10 bits	
Reference video output level	940 steps	
Reference pedestal level	64 steps	
White clip	1023 steps	
Output signal frequency	59.94 Hz (Internal clock, normal mode)	29.2 Hz (Internal clock, normal mode)
Horizontal resolution	500TV lines	800TV lines
Sensitivity	400 lx F5.6 (0 dB)	
Minimum illumination	1 lx (with the gain control at maximum, F1.4)	
Gain	0 to +18 dB	
Gamma	1 (fixed)	
Read mode	Normal/Bining/High rate scan	
Shutter mode	External trigger shutter	
Shutter speed	External trigger shutter: 1/4 to 1/100000 s	
Frame rate	59.94 fps	
Output data clock	24.55 MHz	
High rate scan	ON/OFF	
Bining	Vertical +2Line	Vertical +2Line
Power requirements	+12V DC (Range: +10.5 to 15V)	
Power consumption	2.0 W	2.2 W
Dimensions (W x H x D)	29 (W) x 29 (H) x 30 (D) mm	
Mass	55 g	
Operating temperature	-5 to +45 °C	
Storage temperature	-30 to +60 °C	
Operating humidity	20 to 80 % (no condensation)	
Storage humidity	20 to 95 % (no condensation)	
Vibration resistance	10G (20 Hz to 200 Hz, 20 minutes for each direction-X, Y, Z)	
Shock resistance	70G	
MTBF	73,880 hrs.	
Regulation	UL60905, VCCI Class B, FCC Class B, CE(EN61326/97+A1/98), Australia EMC(AS4251.1+AS4252.1)	
Supplied accessories	Lens mout cap(1) Operating Instructions(1)	

## Location and Function of Parts and Controls

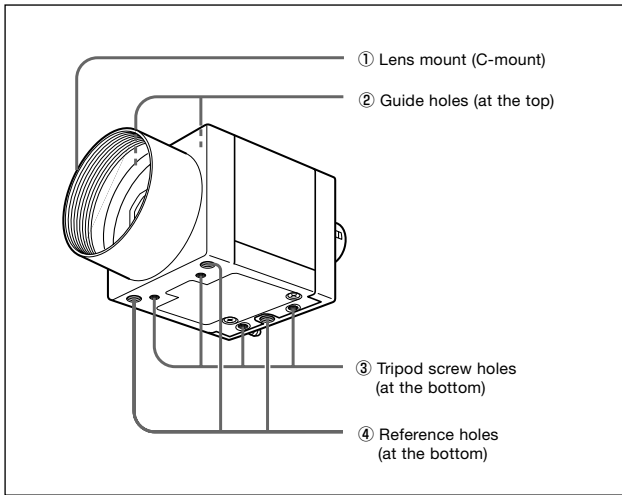

### ① Lens mount (C-mount)

Attach any C-mount lens, such as the VCL-12YM standard lens, or other optical equipment.

#### Note

Be sure that the lens does not project more than 10 mm from the lens mount.

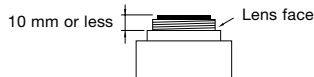

### ② Guide holes (at the top)

These screw holes help to lock the camera module.

### ③ Tripod screw holes (at the bottom)

These four screw holes on the bottom are for installing the camera module on a tripod. To install on a tripod, you will need to install the VCT-3331 tripod adaptor using these holes on the bottom of the camera.

### ④ Reference holes (at the bottom)

These precision screw holes are for locking the camera module. Locking the camera module using these holes secures the optical axis alignment.

## Rear Panel

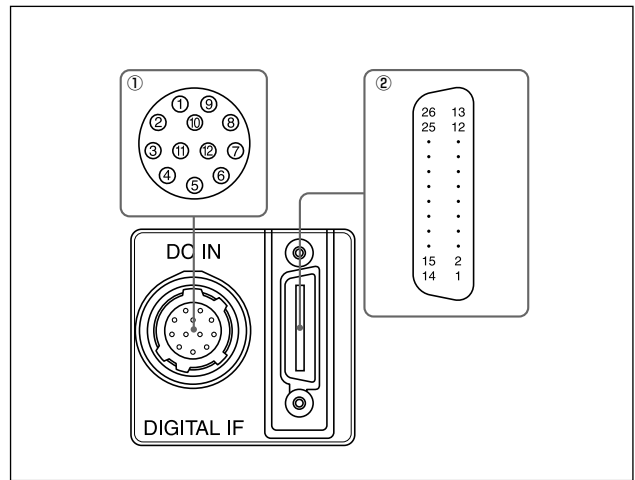

### ① DC IN (DC power input) connector (12-pin)

You can connect a CCXC-12P05N camera cable to input the +12 V DC power supply. When a sync signal generator is connected to this connector, the camera module is synchronized with the external sync signals. The pin configuration of this connector is as follows.

### ② DIGITAL IF (Interface) connector (26-pin)

You can connect a Camera Link cable to this connector to control a camera module from a host device utilizing the serial communication protocol while outputting a video signal from the camera module. You can input the external trigger signal/external sync signal via the 26-pin connector and operate a camera module in the external trigger mode/external synchronization mode. The pin configuration of this connector is as follows.

#### Note

When you operate a camera module by inputting an external trigger signal via the 26-pin connector, make sure to input external trigger signals that meet the following specifications to both the two pins.

Specifications for the External Trigger Signal

Amplitude: LVDS using a 3.3 volt IC      Polarity: positive



Connections: Input a TRIG (-) signal to the 9th pin.

Input a TRIG (+) signal to the 22nd pin.

## Connector Pin Assignments

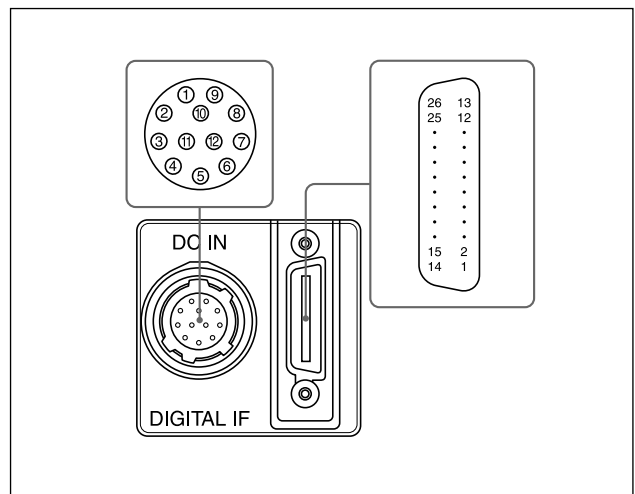

Pin No.	Camera sync output	External Sync mode (HD/VD)	Restart reset	External trigger shutter
1	Ground	Ground	Ground	Ground
2	+12 V DC	+12 V DC	+12 V DC	+12 V DC
3	—	—	—	—
4	Clock (+) input (Signal)	Clock (+) input (Signal)	Clock (+) input (Signal)	Clock (+) input (Signal)
5	HD output (Ground)	HD input (Ground)	HD input (Ground)	HD input (Ground)
6	HD output (Signal)	HD input (Signal)	HD input (Signal)	HD input (Signal)
7	VD output (Signal)	VD input (Signal)	Reset (Signal)	VD input (Signal)
8	—	—	—	—
9	Clock (-) input (Signal)	Clock (-) input (Signal)	Clock (-) input (Signal)	Clock (-) input (Signal)
10	—	—	—	WEN output (Signal)
11	—	—	—	Trigger pulse input (Signal)
12	VD output (Ground)	VD input (Ground)	Reset (Ground)	VD input (Ground)

#### Note

When you operate a camera module by inputting an external clock signal, input the external signal using the VIDEO connectors of the DC-700. Make sure to input external clock signals that meet the following specifications to both connectors.

Pin No.	Digital signal	Pin No.	Digital signal
1	INNER_SHIELD (Ground)	14	INNER_SHIELD (Ground)
2	X0- output (Signal)	15	X0+ output (Signal)
3	X1- output (Signal)	16	X1+ output (Signal)
4	X2- output (Signal)	17	X2+ output (Signal)
5	XCLK- output (Signal)	18	XCLK+ output (Signal)
6	X3- output (Signal)	19	X3+ output (Signal)
7	Ser TC+ (Signal)	20	Ser TC- (Signal)
8	Ser TFG- (Signal)	21	Ser TFG+ (Signal)
9	TRIG (-) input (Signal)	22	TRIG (+) input (Signal)
10	HD (+) input (Signal)	23	HD (-) input (Signal)
11	VD (-) input (Signal)	24	VD (+) input (Signal)
12	CLOCK (+) input (Signal)	25	CLOCK (-) input (Signal)
13	INNER_SHIELD (Ground)	26	INNER_SHIELD (Ground)

## Connecting the cables

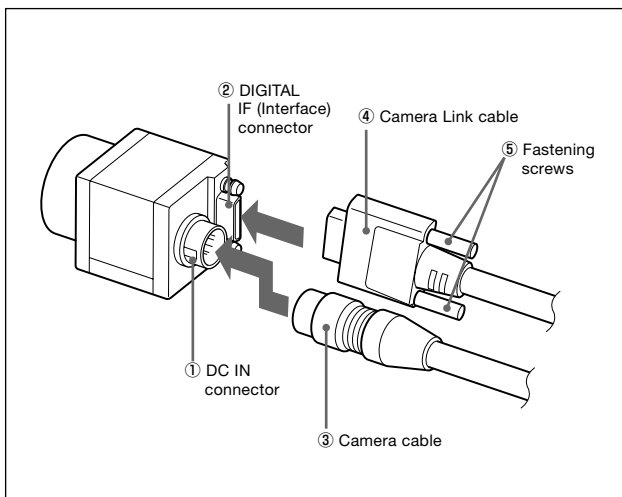

Connect the Camera cable to the DC IN connector and the Camera Link cable to the DIGITAL IF (Interface) connector respectively. When you connect the Camera Link cable, turn the two Fastening screws on the connector to secure the cable tightly. Connect the other end of the Camera cable to the DC-700/700CE and the other end of the Camera Link cable to the camera module interface board.

## About the camera control method

You can control the camera from host device such as a PC. The following table shows the control functions.

You can send a command corresponding to the control items, with parameters for the desired settings, if necessary, from the host device to control the camera.

Control functions	Description	
Operating mode	Normal/Restart reset/trigger mode 1/trigger mode 2	
Shutter speed	Normal	XCL-X700: OFF (1/29.2) to 1/20000 XCL-V500: OFF (1/60) to 1/30000
	Trigger	Internal setting: OFF (the same as above) to 1/100000 Setting by trigger pulse width
Gain	0 to +18 dB	
Binning function	OFF/ON	
Partial Scan function	OFF/ON	
HD/VD signal I/O signal output	External sync signal input / Internal sync	
External trigger input	26-pin connector / DC-700/700CE	
75 Ω termination	ON/OFF	
Master clock	Internal / External	

#### Note

Make sure to supply power to the camera module and confirm that the camera module is operating before inputting a sync or trigger signal. If you input external signals to a camera module without the power supplied, this may cause a malfunction of the camera module.

## Trigger Pulse Specifications

### DC IN connector

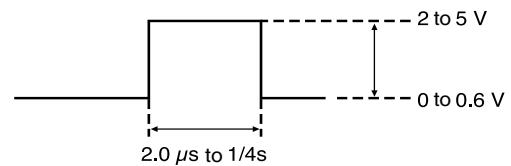

The voltage measured when the input impedance is 10 kΩ or more

### DIGITAL IF connector

Input signals meeting the input specifications above converted to the signal level of the LVDS system (output by the 3.3 V IC). Be aware that if the signals fail to meet the following conditions, the camera module will not recognize the input signals properly.

H level: 1.5 V to 1.7 V  
L level: 0.8 V to 1.0 V

## WEN Output Specifications (only for the DC connector)

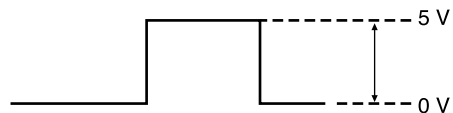

The voltage measured when terminated with 10 kΩ or more

Output WEN signals synchronized with the falling edge of Internal-VD, corresponding to the start of video signal output in Trigger Mode1/2.