

Digital Video Camera Module

Technical Manual

XCL-X700/V500

Table of Contents

Overview

What is the Camera Link?	4
Features	4
System Components	6
Connection Diagram	6
Location and Function of Parts and Controls	7
Front/Top/Bottom	7
Rear	8
Connecting the cables	9

Functions of the XCL-X700

About the Camera Modes	11
■ Normal Mode (when operating in external synchronization)	11
■ Restart/ Reset mode (when operating in external synchronization)	11
■ Trigger Mode1 (when operating in external synchronization with the shutter operation controlled by a trigger pulse width)	12
■ Trigger Mode2 (when operating in internal synchronization with the shutter operation controlled by a trigger pulse width)	12
About the Camera Functions	13
■ Electronic Shutter Function	13
■ Overlap Function	13
■ External Clock Input Function	15
■ Binning Function	16
■ High-rate scan I Function	17
■ High-rate scan II Function	19
Input/Output Signal Specifications	24
■ External-HD/VD input phase specifications	24
■ External-HD Input Specifications	25
■ External-VD Input Specifications	25
■ HD/VD Output Specifications (only for the DC IN connector)	25
■ Trigger Pulse Specifications	26
■ WEN Output Specifications (only for the DC IN connector)	26
■ DVAL/LVAL/FVAL Output Specifications (only for the DIGITAL IF connector)	26
■ External-CLK Specifications (common to the DC IN /DIGITAL IF connectors)	26
CCD Output Waveform Timing Chart	27

Functions of the XCL-V500

About the Camera Modes	28
■ Normal Mode (when operating in external synchronization)	28
■ Restart/ Reset mode (when operating in external synchronization)	28

■ Trigger Mode1 (when operating in external synchronization with the shutter operation controlled by a trigger pulse width)	29
■ Trigger Mode2 (when operating in internal synchronization with the shutter operation controlled by a trigger pulse width)	29
About the Camera Functions	30
■ Electronic Shutter Function	30
■ Overlap Function	30
■ External Clock Input Function	32
■ Binning Function	33
■ High-rate scan I Function	34
■ High-rate scan II Function	36
Input/Output Signal Specifications	39
■ External-HD/VD input phase specifications	39
■ External-HD Input Specification	40
■ External-VD Input Specifications	40
■ HD/VD Output Specifications (only for the DC IN connector)	40
■ Trigger Pulse Specifications	41
■ WEN Output Specifications (only for the DC IN connector)	41
■ LVAL/FVAL Output Specifications (only for the DIGITAL IF connector)	41
■ External-CLK Specifications (common to the DC IN /DIGITAL IF connectors)	41
CCD Output Waveform Timing Chart	42

Camera Control Command

Overview	43
Serial Communication Specifications	43
Command System	43
Command Format	43
Command Input and Response	43
Command Specifications	44
Camera Control Commands	44
Setting Value Control Commands	46
Other Commands	46
Command List	47

Specifications

Specifications	48
Spectral Sensitivity Characteristics (Typical Values)	49
XCL-X700 Dimensions	50
XCL-V500 Dimensions	51

Appendix

Available Accessory Lenses	52
---	-----------

Overview

The XCL-X700/V500 is a monochrome digital video camera module. This camera module outputs digital images utilizing LVDS via the digital interface connector.

What is the Camera Link?

The Camera Link is specifications defined for industrial cameras, and the term used collectively for all products meeting these specifications. In the Camera Link specification, digital parallel signals are converted to LVDS serial signals and sent out from the camera module. These signals are sent to the interface board for the camera (frame grabber) via the cable, and decoded to the original digital parallel signals in the interface board. The XCL-X700/V500 is equipped with a connector compatible with the Camera Link specifications, and can be connected to any interface board compatible with the XCL-X700/V500 using the specified standard cable.

Features

Digital interface connector

Equipped with a Camera Link compatible connector. The XCL-X700 can output a digital image at 30 frames per second; the XCL-V500 can output a digital image at 60 frames per second.

High image quality

The XCL-X700 (XGA) has a progressive scan CCD of 800,000 pixels. The XCL-V500 (VGA) has a progressive scan CCD of 330,000 pixels. Both cameras produce high-resolution images. By adopting square pixels, images can be processed using the original aspect ratio without a converting procedure.

Various mode settings

Sending a command from the host device allows the following mode settings.

- Gain
- Read mode: normal /binning
- High rate scan
- Synchronized input/output
- 75 Ω termination
- Shutter: Normal/Trigger shutter
- Shutter speed

External synchronization

HD (horizontal drive), VD (vertical drive) signals: The camera module automatically detects the HD and VD signals input and externally synchronized with those signals.

Setting the operating speed by inputting an external clock

You can operate the camera module at the desired clock frequency (frame rate) by inputting external clock signals of an arbitrary frequency from normal to 1/2.

Internal sync signal output

You can output HD or VD signals from the 12-pin connector by changing the setting using a command sent from the host device.

Electronic shutter function

Shutter speed can be selected from a wide range or in flickerless (FL) mode.

External trigger shutter function (1/4 to 1/100000 sec.)

You can obtain a freeze picture by inputting an external trigger. This function is useful to shoot a fast-moving object clearly.

High rate scan

The camera module can limit the number of effective video output lines to achieve high frame rates, enabling high-speed image processing.

Binning

By “binning” two pixels that align vertically, you can acquire sensitivity as well as a frame rate twice as high as those in the normal mode, when using the electronic shutter.

Body fixing

The screw holes to install the camera module are located under the front panel (the CCD reference plane). Installing the camera module using these holes minimizes deviation of the optical axis.

Note

The CCD is driven at high speed during a High-rate scan or Binning operation. In this situation, if intense light is input to the camera, the peripheral areas of the video image may be affected. In such a situation, adjust the amount of light using the iris.

System Components

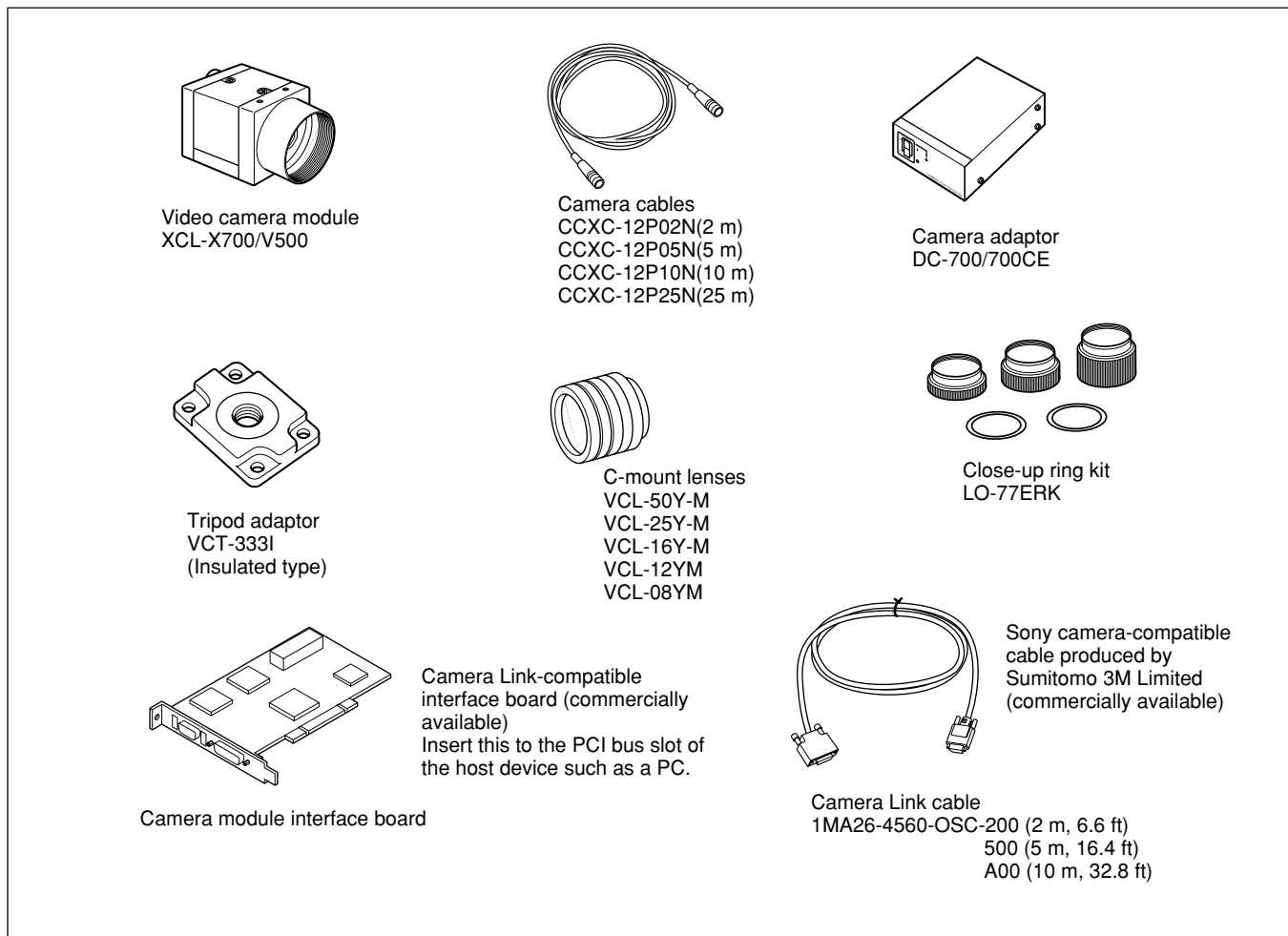

Connection Diagram

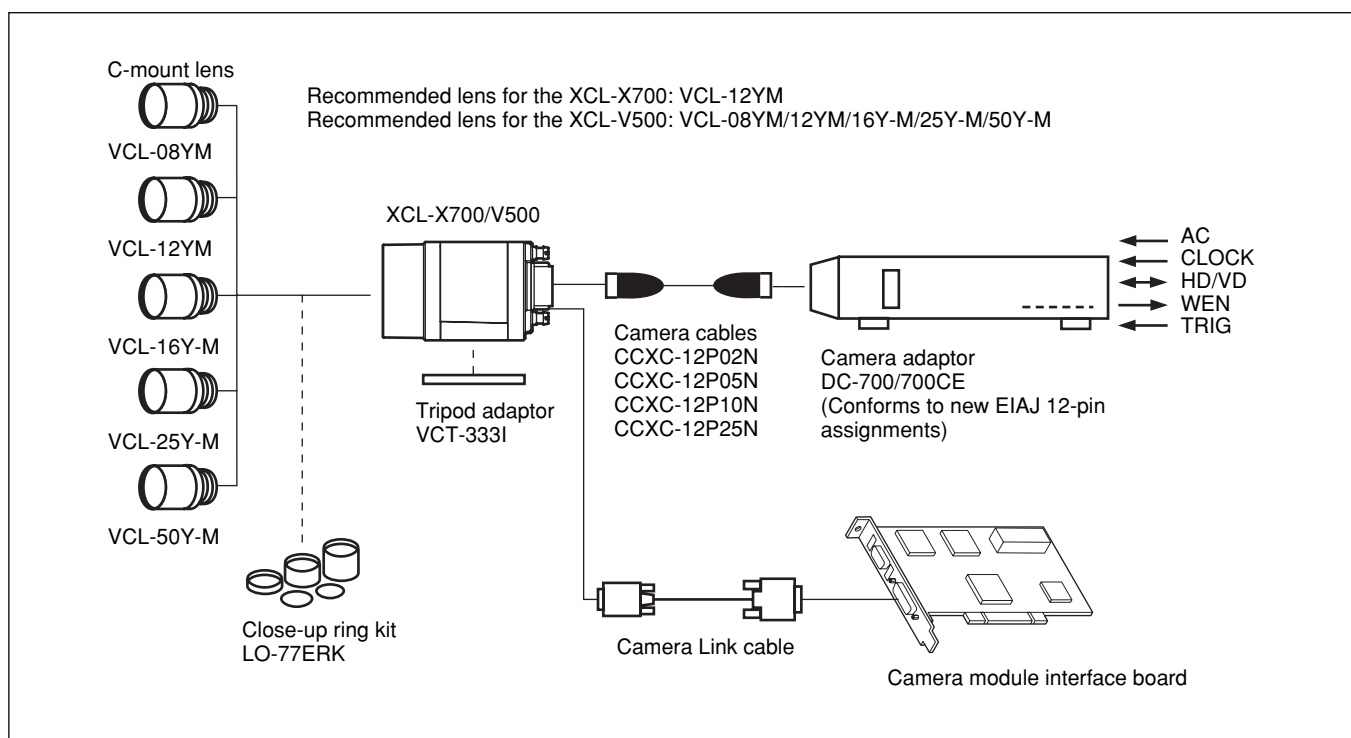

Location and Function of Parts and Controls

Front/Top/Bottom

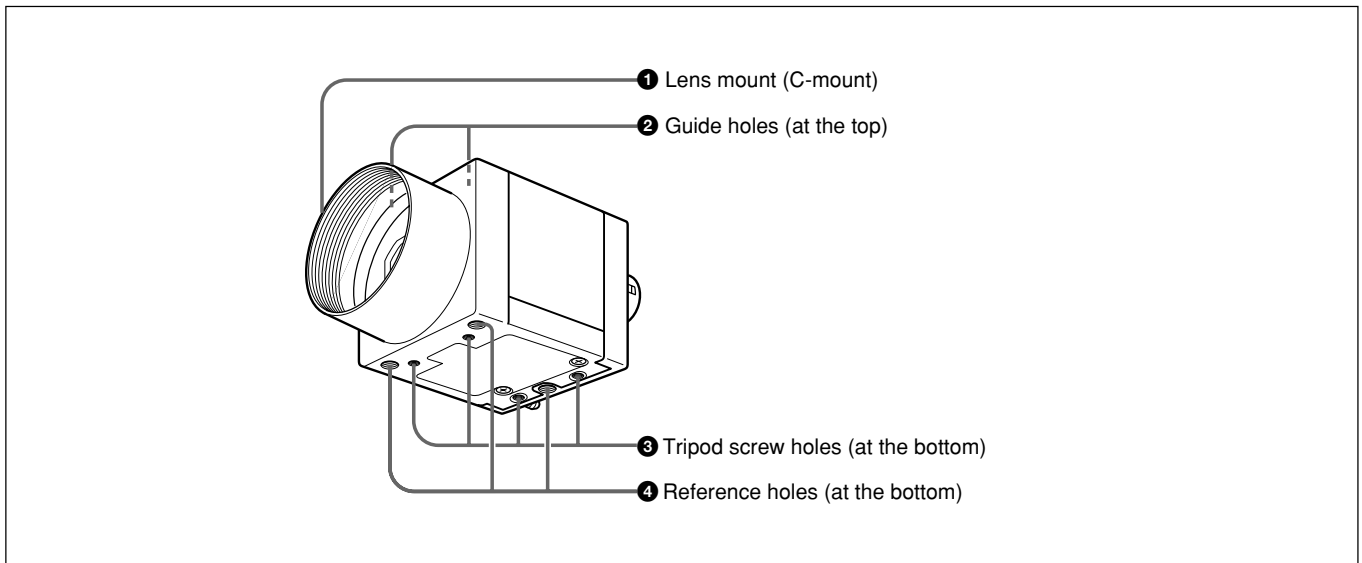

❶ Lens mount (C-mount)

Attach any C-mount lens, such as the VCL-12YM standard lens, or other optical equipment.

Note

Be sure that the lens does not project more than 7 mm (9/32 inch) from the lens mount.

❷ Guide holes (at the top)

These screw holes help to lock the camera module.

❸ Tripod screw holes (at the bottom)

These four screw holes on the bottom are for installing the camera module on a tripod. To install on a tripod, you will need to install the VCT-333I tripod adaptor using these holes on the bottom of the camera.

❹ Reference holes (at the bottom)

These precision screw holes are for locking the camera module. Locking the camera module using these holes secures the optical axis alignment.

Rear

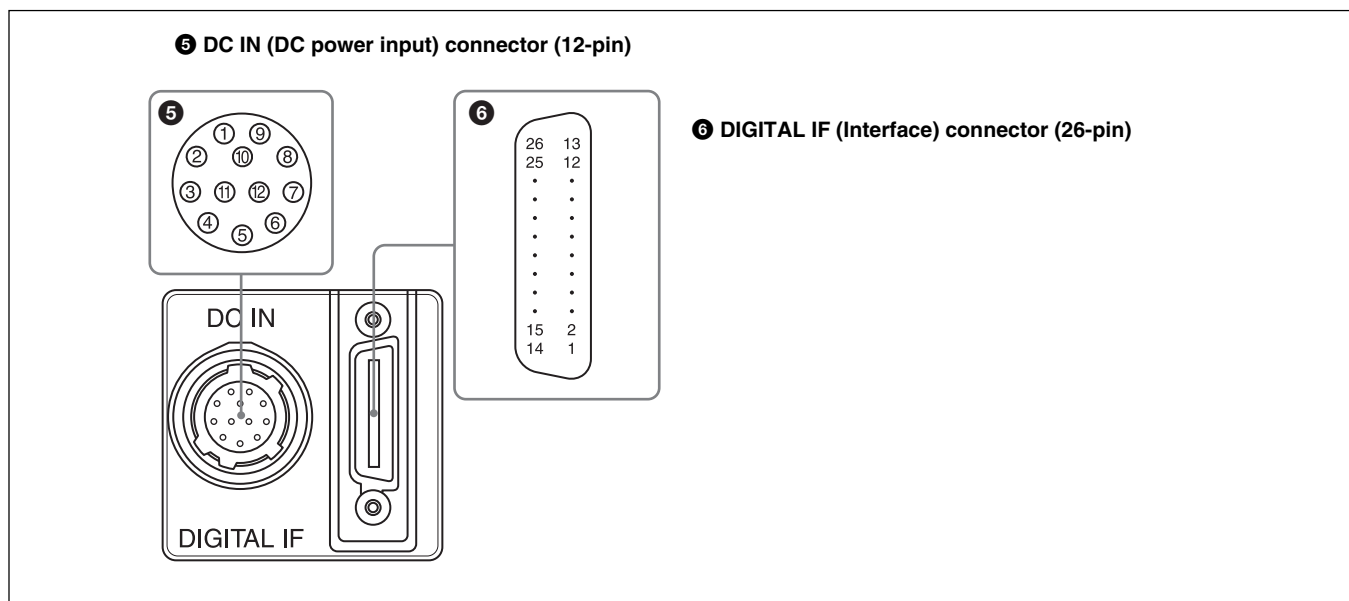

5 DC IN (DC power input) connector (12-pin)

You can connect a CCXC-12P05N camera cable to input the +12 V DC power supply. When a sync signal generator is connected to this connector, the camera module is synchronized with the external sync signals. The pin configuration of this connector is as follows.

Pin No.	Camera sync output	External Sync mode (HD/VD)	Restart reset	External trigger shutter
1	Ground	Ground	Ground	Ground
2	+12 V DC	+12 V DC	+12 V DC	+12 V DC
3	—	—	—	—
4	Clock (+) input (Signal)	Clock (+) input (Signal)	Clock (+) input (Signal)	Clock (+) input (Signal)
5	HD output (Ground)	HD input (Ground)	HD input (Ground)	HD input (Ground)
6	HD output (Signal)	HD input (Signal)	HD input (Signal)	HD input (Signal)
7	VD output (Signal)	VD input (Signal)	Reset (Signal)	VD input (Signal)
8	—	—	—	—
9	Clock (-) input (Signal)	Clock (-) input (Signal)	Clock (-) input (Signal)	Clock (-) input (Signal)
10	—	—	—	WEN output (Signal)
11	—	—	—	Trigger pulse input (Signal)
12	VD output (Ground)	VD input (Ground)	Reset (Ground)	VD input (Ground)

Note

When you operate a camera module by inputting an external clock signal, input the external signal using the VIDEO connectors of the DC-700. Make sure to input external clock signals that meet the following specifications to both connectors.

Specifications for the external clock signal
 Amplitude: LVDS (Low-Voltage Differential Signaling) system using a 3.3 volt IC.
 Frequency: XCL-X700: 29.5 MHz to 59.0 MHz
 XCL-V500: 24.545 MHz to 49.09 MHz
 Connections: Input a CLOCK (+) signal to the VIDEO 1 connector of the DC-700.
 Input a CLOCK (-) signal to the VIDEO 2 connector of the DC-700.

⑥ DIGITAL IF (Interface) connector (26-pin)

You can connect a Camera Link cable to this connector to control a camera module from a host device utilizing the serial communication protocol while outputting a video signal from the camera module. You can input the external trigger signal/ external sync signal via the 26-pin connector and operate a camera module in the external trigger mode/ external synchronization mode. The pin configuration of this connector is as follows.

Pin No.	Digital signal	Pin No.	Digital signal
1	INNER_SHIELD (Ground)	14	INNER_SHIELD (Ground)
2	X0- output (Signal)	15	X0+ output (Signal)
3	X1- output (Signal)	16	X1+ output (Signal)
4	X2- output (Signal)	17	X2+ output (Signal)
5	XCLK- output (Signal)	18	XCLK+ output (Signal)
6	X3- output (Signal)	19	X3+ output (Signal)
7	Ser TC+ (Signal)	20	Ser TC- (Signal)
8	Ser TFG- (Signal)	21	Ser TFG+ (Signal)
9	TRIG (-) input (Signal)	22	TRIG (+) input (Signal)
10	HD (+) input (Signal)	23	HD (-) input (Signal)
11	VD (-) input (Signal)	24	VD (+) input (Signal)
12	CLOCK (+) input (Signal)	25	CLOCK (-) input (Signal)
13	INNER_SHIELD (Ground)	26	INNER_SHIELD (Ground)

Note

When you operate a camera module by inputting an external trigger signal via the 26-pin connector, make sure to input external trigger signals that meet the following specifications to both the two pins.

Specifications for the External Trigger Signal
Amplitude: LVDS using a 3.3 volt IC Polarity: positive



Connections: Input a TRIG (-) signal to the 9th pin.
Input a TRIG (+) signal to the 22nd pin.

Connecting the cables

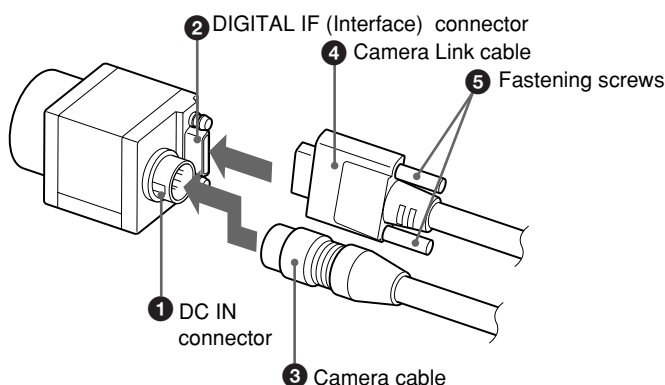

Connect the Camera cable to the DC IN connector and the Camera Link cable to the DIGITAL IF (Interface) connector respectively. When you connect the Camera Link cable, turn the two Fastening screws on the connector to secure the cable tightly.

Connect the other end of the Camera cable to the DC-700/700CE and the other end of the Camera Link cable to the camera module interface board.

About the camera control method

You can control the camera from host device such as a PC. The following table shows the control functions. You can send a command corresponding to the control items, with parameters for the desired settings, if necessary, from the host device to control the camera. Refer to “Camera Control Command” on page 43 for details on how to send a command, the commands, and their parameters.

Control functions	Description	
Operating mode	Normal/Restart reset/trigger mode 1/ trigger mode 2	
Shutter speed	Normal	XCL-X700: OFF ($1/30$) - $1/20000$
		XCL-V500: OFF ($1/60$) - $1/30000$
	Trigger	Internal setting: OFF (the same as above) - $1/100000$
		Setting by trigger pulse width
Gain	0 to +18 dB	
Binning function	OFF/ON	
High-rate Scan function	OFF/ON	
HD/VD signal I/O signal output	External sync signal input / Internal sync	
External trigger input	26-pin connector / DC-700/700CE	
75 Ω termination	ON/OFF	
Master clock	Internal / External	

Note

Make sure to supply power to the camera module and confirm that the camera module is operating before inputting a sync or trigger signal. If you input external signals to a camera module without the power supplied, this may cause a malfunction of the camera module.

Functions of the XCL-X700

About the Camera Modes

■ Normal Mode (when operating in external synchronization)

Description: Outputs each independent pixel video signal for 1/29.2 second. Internal or external synchronization is recommended.

Application: Use this mode to provides continuous standard video output.

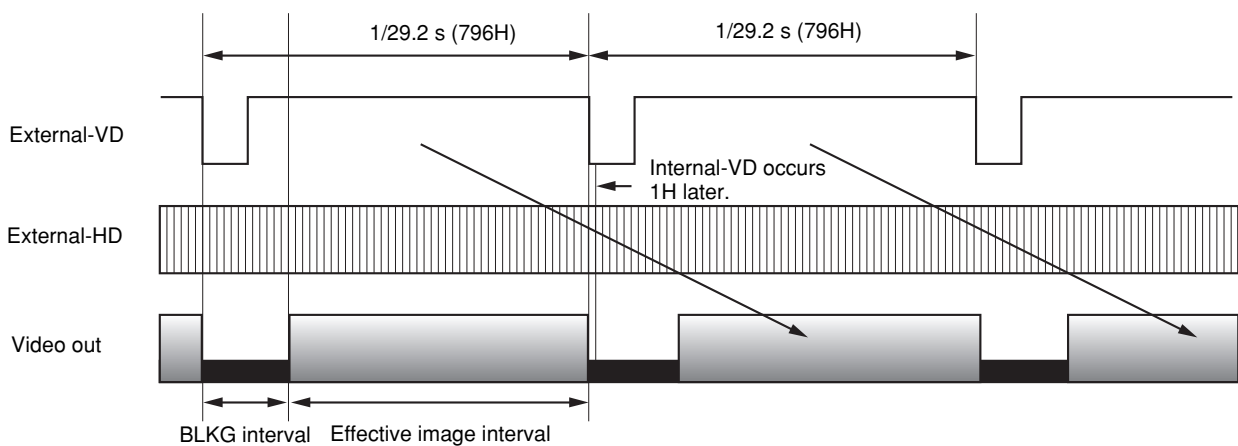

■ Restart/ Reset mode (when operating in external synchronization)

Description: Outputs each independent pixel video signal of a single shot for which exposure time is proportional to the interval of External-VD signals, synchronized with External-VD signals. External synchronization is recommended.

satisfactory sensitivity in the Normal Mode, or when you want to observe the trail of a moving object.

Application: Use this mode when you cannot gain

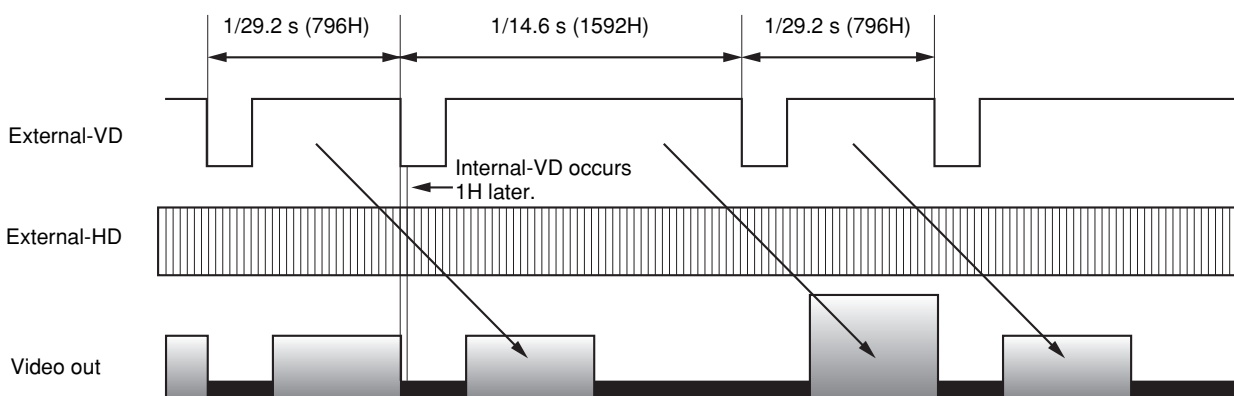

■ Trigger Mode1 (when operating in external synchronization with the shutter operation controlled by a trigger pulse width)

Description: Controls the shutter synchronized with externally input trigger signals and outputs each independent pixel video signal of a single shot synchronized with External-VD signals. External synchronization is recommended. We recommend that external trigger signals, External-VD signals, and External-HD signals are all synchronized with each other, and the ratio of the external trigger

signals and the External-VD signals should be 1:1. When you use the fixed speed trigger shutter, input the External-VD signals synchronized to the output.

Application: Use this mode to capture fast-moving objects in a precise position synchronized with External-VD signals because in this mode, the shutter is controlled by inputting external trigger signals.

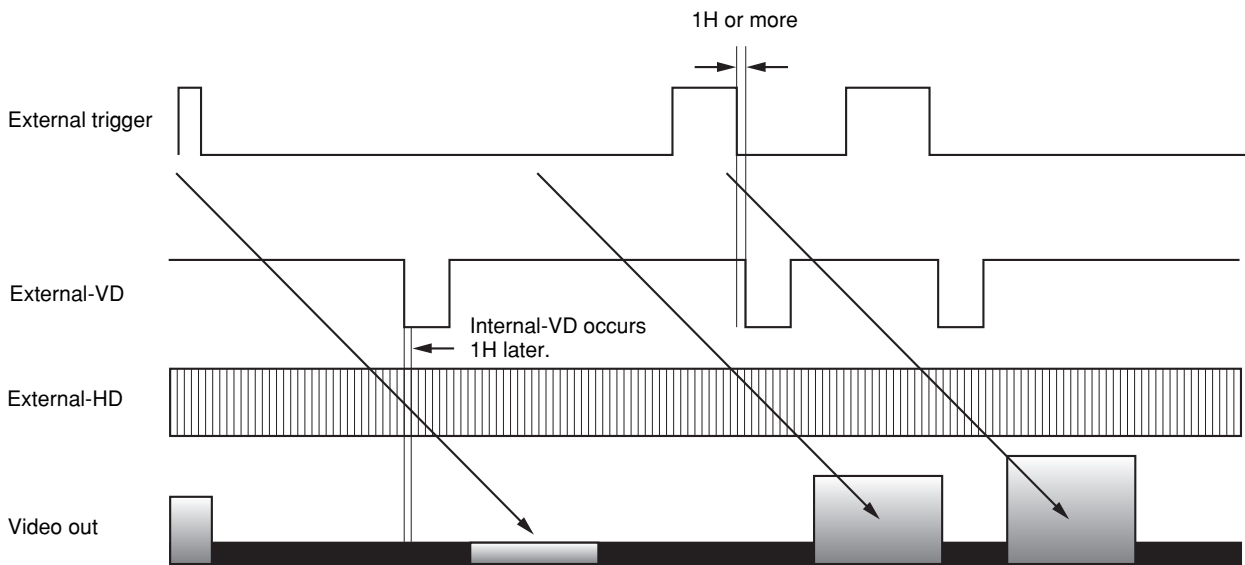

■ Trigger Mode2 (when operating in internal synchronization with the shutter operation controlled by a trigger pulse width)

Description: Controls the shutter synchronized with externally input trigger signals and outputs each independent pixel video signal of a single shot in synchronization with externally input trigger signals after a certain period. Internal or external synchronization is recommended.

Application: Use this mode to obtain video output synchronized with externally input trigger signals after a certain period without inputting External-VD signals as in case of the Trigger Mode1.

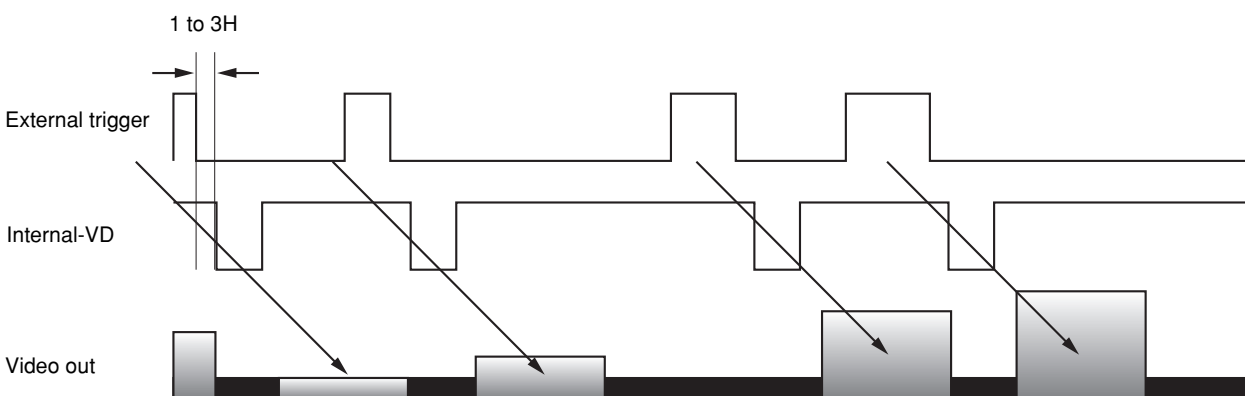

About the Camera Functions

■ Electronic Shutter Function

Normal Shutter

The electronic shutter is used for continuous video output to capture fast-moving objects clearly. Shutter speeds of 1, 1/100, 1/125, 1/250, 1/500, 1/1000, 1/2000, 1/4000, 1/10000, 1/20000 second are supported. Normal Mode is supported for the Camera Mode.

External Trigger Shutter

The electronic shutter is used synchronized with externally input trigger signals to capture fast-moving objects clearly and in a precise position. There are two types of external trigger shutter: an external trigger shutter controlled by external input trigger pulse width and a fixed speed external trigger shutter synchronized with the timing of an externally input trigger. Trigger Model 1 and Trigger Mode 2 are both supported for the Camera Mode.

- **Fixed external trigger shutter speeds:**
1, 1/100, 1/125, 1/250, 1/500, 1/1000, 1/2000, 1/4000, 1/10000, 1/25000, 1/50000, 1/100000 second are supported.
- **External trigger shutter speed is**

controlled by external trigger pulse width:
You can obtain an arbitrary shutter speed by setting the external trigger pulse width to the range of 2 μsec to 1/4 sec.

- When trigger signals are input through the 12-pin connector
External trigger pulse width shutter speed = external trigger pulse width + 6 μsec
- When trigger signals are input through the DIGITAL IF connector
External trigger pulse width shutter speed = external trigger pulse width + 5 μsec

■ Overlap Function

One way to increase frame rate while using slow to mid-speed trigger pulse width shutter in the case of previous analog cameras ① is to input the rising edge of the external trigger signals during the effective image interval as indicated in case ②. Noise is generated when the rising edge of the external trigger signal is input during the effective image interval, however, and the effective video output deteriorates and becomes unusable. As a consequence, we must input the signal after the effective image interval and we cannot increase frame rate indicated as T2 in the case of ②.

The frame rate results in:

$$T1 = \text{approx. Effective image interval} + \text{exposure time}$$

controlled by the trigger signals

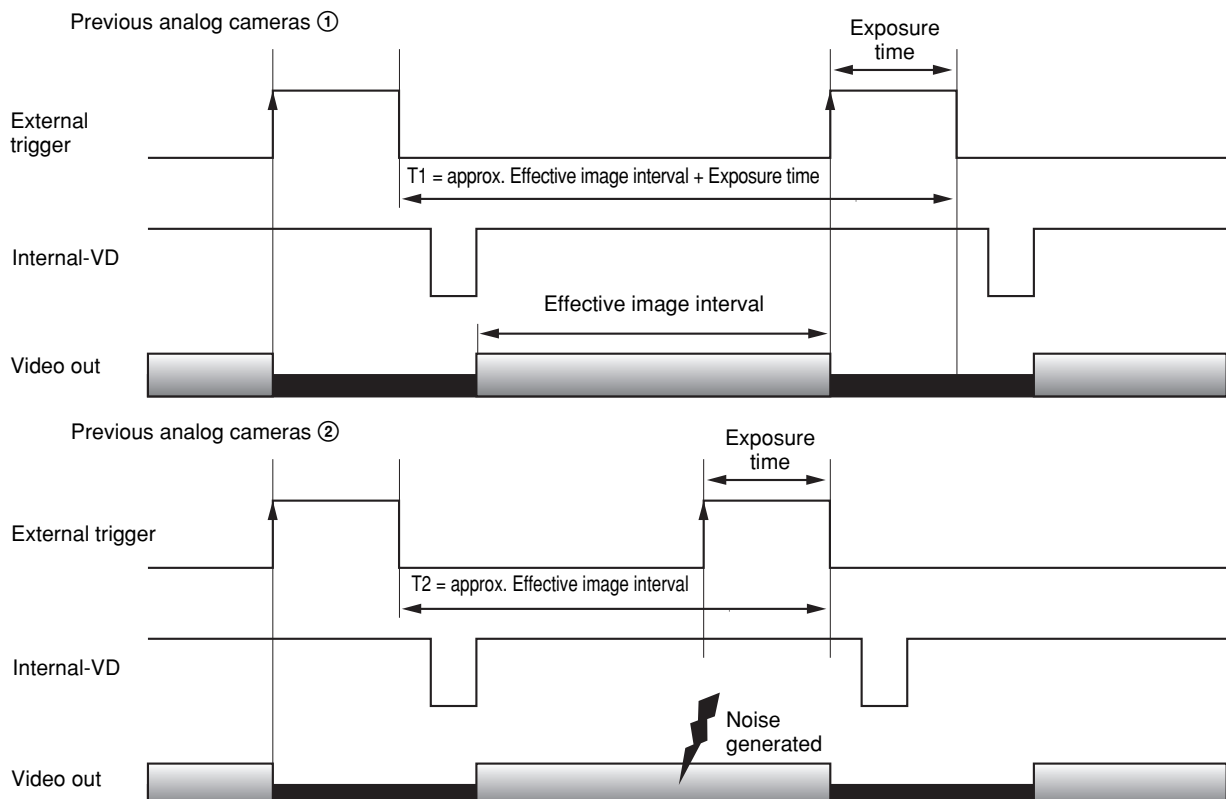

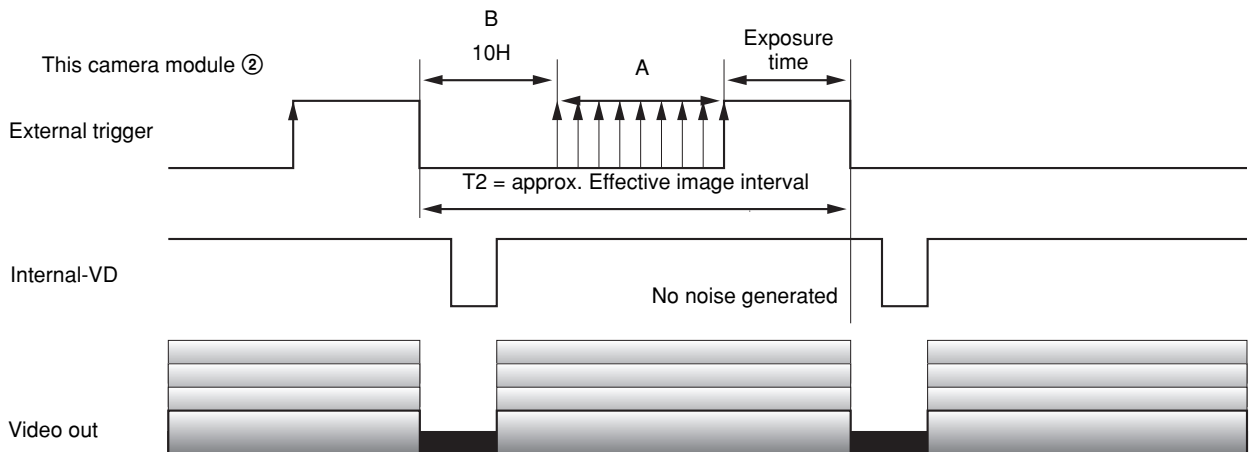
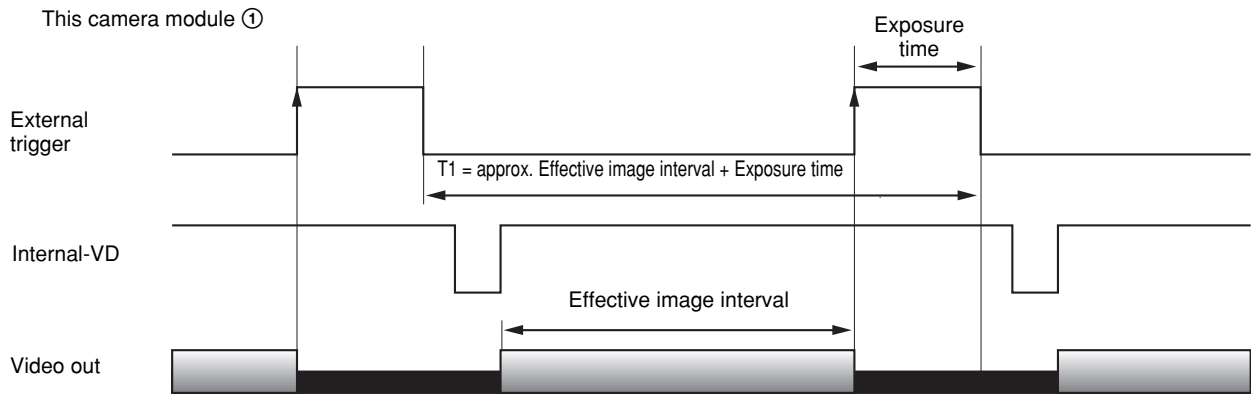

This camera is equipped with an Overlap function which eliminates the effect of noise accompanying the increase of frame rate while using a slow to mid-speed shutter. This camera module can be used in the operation mode that can increase frame rate without noise generation as indicated in ② as well as that in ① that is equal to the operation of previous analog cameras. Thanks to this function, exposure time can be prolonged, and shutter speed can be slowed down, keeping a high frame rate by putting the rising edge of the external trigger earlier as indicated by A in ②. Be aware that the maximum interval in which you can input the rising edge of the external trigger is in the range of 10 H after the falling edge of the previous trigger to the rising edge of the next trigger as indicated by B in ②. Trigger Mode1 and 2 are supported for the Camera Mode.

Notes

- The description above is the operation while using a slow to mid-speed shutter controlled by the external trigger pulse width. When using a fixed speed external trigger shutter, be sure to input the rising edge of the next trigger after the internal exposure time and at the appropriate timing so as not to affect the effective image interval corresponding to the current trigger signal. Be aware that if this condition is not observed, the following may occur.
 - To which frames the effective images corresponding to the external trigger signals will be output may be inconsistent.
 - Double exposure
 - Signals in the blanking interval may be output in the effective image interval.
- If you change settings such as Camera Mode while using the Overlap function, video output may be disturbed.
- A deviation of a maximum about 1H is generated for the exposure time by the Overlap function, so the supported shutter speeds are limited to those for which this exposure deviation can be ignored.

External Clock Input Function

Previously, the operating speed of a camera was fixed. This camera can change its operating speed from the normal speed to half of that.

By utilizing the external clock input function, clock jitter is completely eliminated. All modes are supported for the Camera Mode.

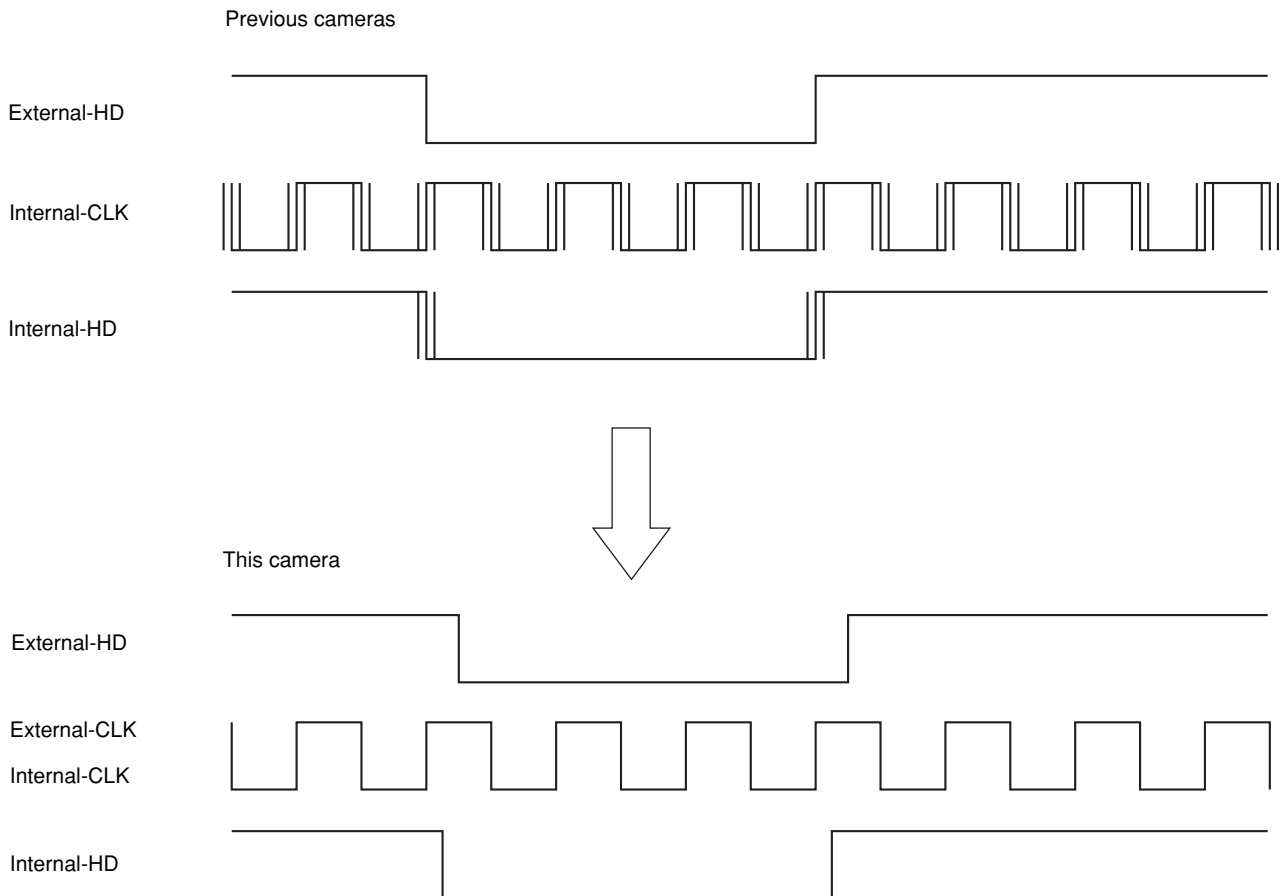

Notes

- Be aware that the shift of phase occurs in the range of $-2 \times \text{CLK}$ to 0 (reference: External-CLK) for Internal-HD signals depending on the timing when the power is turned on. The amount of the shift is not always the same and varies within the range described above every time the power is turned on.
- Be aware that noise is generated when the Internal/ External clock is switched.

The speed of the electronic shutter is determined by the frequency of the external input clock signals. Calculate the shutter speed according to the following formula.

Normal shutter speed:

$$\text{Exposure time} = \{ 1106 \times A + 164 \times (A-1) \times 187 \} \times 2/\text{ECLK}$$

$$\text{Shutter speed} = 1/\text{Exposure time}$$

A:	1	(1/20000 s)
	2	(1/10000 s)
	6	(1/4000 s)
	12	(1/2000 s)
	23	(1/1000 s)
	46	(1/500 s)
	93	(1/250 s)
	186	(1/125 s)
	232	(1/100 s)

ECLK: External clock frequency: 59 (MAX) to 29.5 (MIN) MHz

Fixed external trigger shutter speeds:

$$\text{Exposure time} = \{ A + B \times 1270 + 144 \} \times 2/\text{ECLK}$$

$$\text{Shutter speed} = 1/\text{Exposure time}$$

A:	151	B:	0	(1/100000 s)
	446		0	(1/50000 s)
	1036		0	(1/25000 s)
	2806		0	(1/10000 s)
	7231		0	(1/4000 s)
	14606		0	(1/2000 s)
	0		23	(1/1000 s)
	0		46	(1/500 s)
	0		93	(1/250 s)
	0		186	(1/125 s)
	0		232	(1/100 s)

External trigger pulse width shutter speed:

- When trigger signals are input through the 12-pin connector

$$\text{Exposure time} = \{ \text{external trigger pulse width} + 1 \mu\text{s} \} + 144 \times 2/\text{ECLK}$$

- When trigger signals are input through the DIGITAL IF connector

$$\text{Exposure time} = \{ \text{external trigger pulse width} \} + 144 \times 2/\text{ECLK}$$

$$\text{Shutter speed} = 1/\text{Exposure time}$$

Be aware that the external trigger pulse width should be set in the range of 3 μsec to 1/4 sec when inputting external clock signals.

■ Binning Function

Mixed signals for vertically adjacent pixels of the output of the CCD are output in this function and sensitivity and frame rate are approximately doubled. When the Normal shutter is OFF in the Normal Mode, the frame rate is doubled but exposure time is halved, so that the effect of this function is cancelled out as in the Reset/Restart mode. Both sensitivity and frame rate are doubled when the Normal shutter is ON. All modes are supported for the Camera Mode. But High-rate scan II in Trigger Mode2 is not supported.

■ High-rate scan I Function

You can transfer less critical portions of the image except for the important center section of the effective image at high frame rates and obtain image output at high frame rates. This function can be controlled by manipulating the setting of the low width of the External-VD signals and the trigger interval (You also

need to make the external trigger interval setting for Trigger Mode1.)

Only Restart/Reset mode and Trigger Mode1 are supported for the Camera Mode. Only the external trigger pulse width shutter is supported for the electronic shutter.

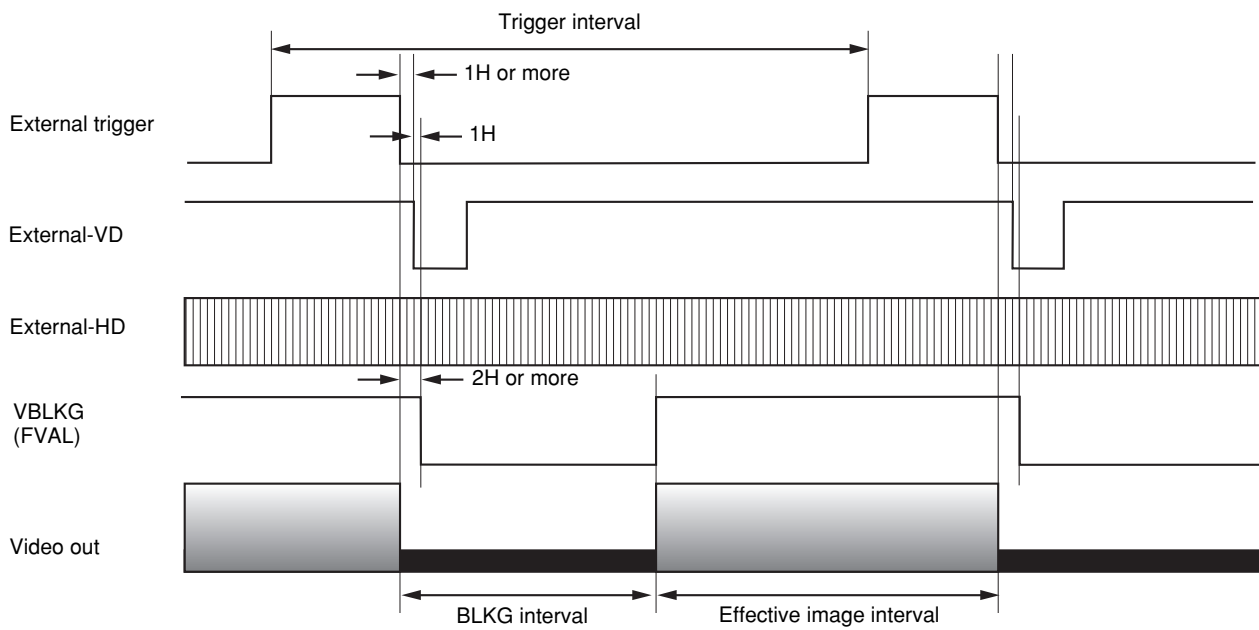
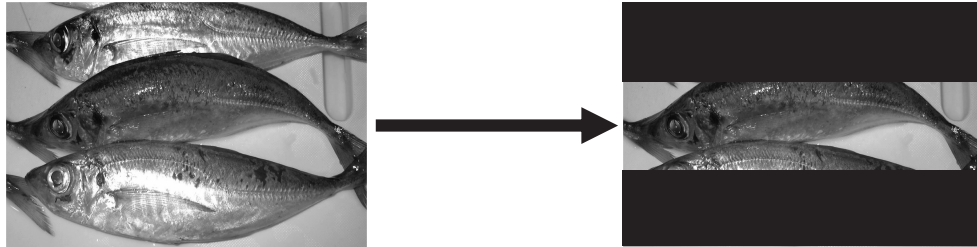

Settings for High-rate scan I

Shaded items are items to be set by the user, after which the following effective lines and frame rates can be obtained.

Restart/Reset Mode Binning: OFF

External-VD interval [H]	External-VD width [H]	BLKG width [H]	Effective Lines [H]
796	High-rate scan I: OFF	28	768
387	22	33	354
258	27	38	220
193	30	41	152

Restart/Reset Mode Binning: ON

External-VD interval [H]	External-VD width [H]	BLKG width [H]	Effective Lines [H]
398	High-rate scan I: OFF	28	370
193	22	33	160
129	27	38	91

Trigger Mode1 Binning: OFF

Trigger interval [H]	External-VD width [H]	BLKG width [H]	Effective Lines [H]
796	High-rate scan I: OFF	28	766
387	19	30	355
258	24	35	221
193	27	38	153

Trigger Mode1 Binning: ON

Trigger interval [H]	External-VD width [H]	BLKG width [H]	Effective Lines [H]
398	High-rate scan I: OFF	28	368
193	19	30	101
129	24	35	92

Notes

- Frame rate is equal to the External-VD/Trigger interval in the settings indicated above. (This is the highest frame rate.)
- The settings for Trigger Mode1 indicated above apply to the setting of slow to middle shutter speeds while using the Overlap function. For middle to high shutter speeds, follow the settings for High-rate scan II (See page 19 and 20) for External-VD/trigger signals. While in Restart/Reset Mode, the shutter speed is fixed in accordance with the External-VD interval.
- The timing chart indicated on the previous page shows the case of Trigger Mode1. For Restart/ Reset mode, trigger input is ignored.

■ High-rate scan II Function

You can divide the effective image interval vertically into 16 sections and select arbitrary sections as the effective image. You can transfer less critical sections at high frame rates and obtain image output at high frame rates. The frame rate and less critical sections are set by the external trigger input interval and then inputting a command. Necessary sections

corresponding to the effective image interval and less critical sections to be transferred at high frame rates are designated and controlled by FPS/RPS settings. Only Trigger Mode2 is supported for the Camera Mode. Only the external trigger pulse width shutter is supported for the electronic shutter.

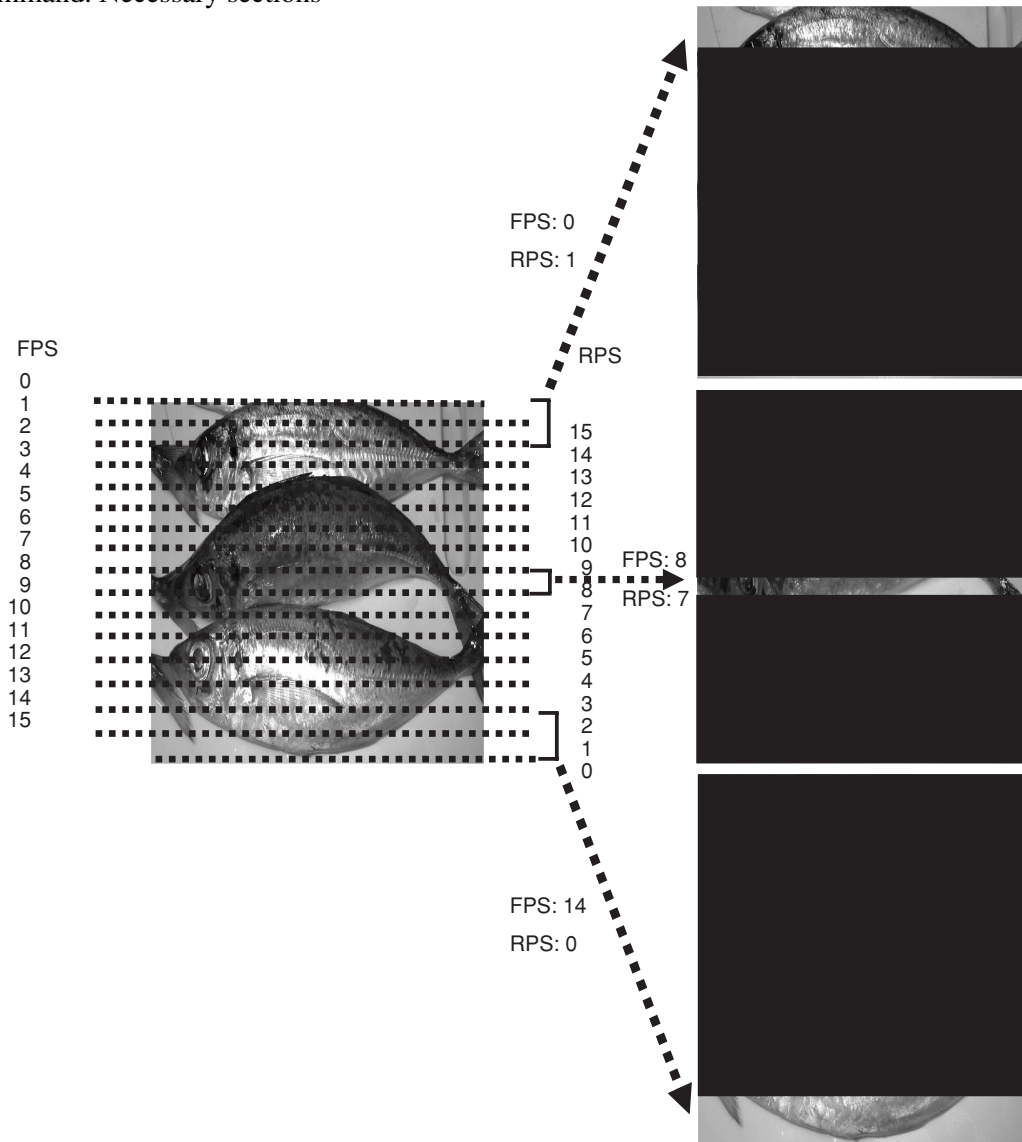

Timing Chart for High-rate scan II while using the Overlap function (slow to mid-speed shutter)

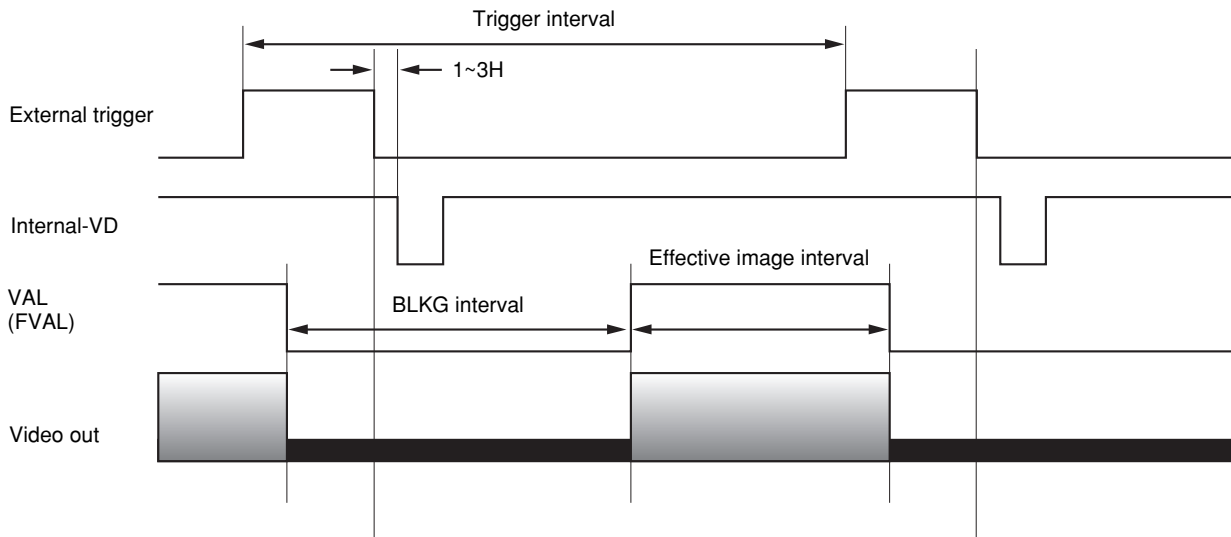

Timing Chart for High-rate scan II while using the Overlap function (middle to high speed shutter)

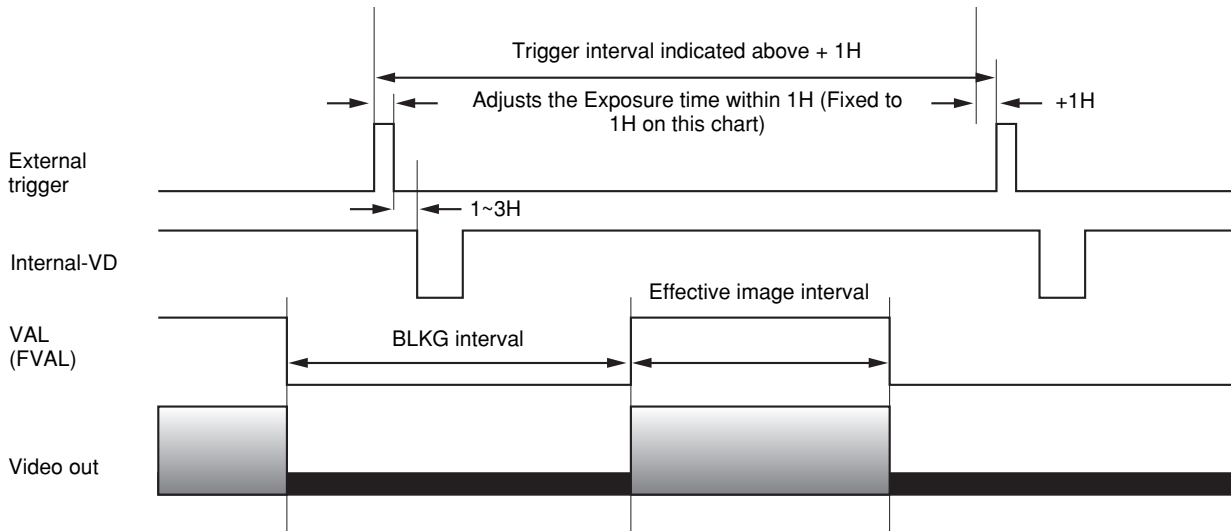

The settings for High-rate scan II on the following page apply to the setting of slow to middle shutter speeds controlled by the external trigger pulse width while using the Overlap function. When using middle to high speed shutter speeds, input the external trigger setting value of the external trigger interval on the following page + 1H without using the Overlap function as indicated in the timing chart above. The

timing chart above shows the case when the exposure time is set to less than 1H. (Change trigger pulse width in accordance with exposure time.) When you want to increase exposure time to 2H or more, increase the external trigger interval 1H by 1H, for example, to +2H, +3H... in accordance with the desired exposure time. Be aware that frame rate is decreased in such a setting.

Settings for High-rate scan II

Shaded items are the items to be set by the user, after which the following effective lines and frame rates can be obtained.

Trigger interval [H]	FPS	RPS	Effective Lines [H]
737	1	0	710
697	2	0	662
657	3	0	614
617	4	0	566
577	5	0	518
537	6	0	470
497	7	0	422
457	8	0	374
417	9	0	326
377	10	0	278
337	11	0	230
297	12	0	182
257	13	0	134
217	14	0	86
117	15	0	38

Trigger interval [H]	FPS	RPS	Effective Lines [H]
751	0	1	720
711	0	2	672
671	0	3	624
631	0	4	576
591	0	5	528
551	0	6	480
511	0	7	432
471	0	8	384
431	0	9	336
391	0	10	288
351	0	11	240
311	0	12	192
271	0	13	144
231	0	14	96
191	0	15	48

Trigger interval [H]	FPS	RPS	Effective Lines [H]
697	1	1	662
657	1	2	614
617	1	3	566
577	1	4	518
537	1	5	470
497	1	6	422
457	1	7	374
417	1	8	326
377	1	9	278
337	1	10	230
297	1	11	182
257	1	12	134
217	1	13	86
117	1	14	38

Trigger interval [H]	FPS	RPS	Effective Lines [H]
657	2	1	614
617	2	2	566
577	2	3	518
537	2	4	470
497	2	5	422
457	2	6	374
417	2	7	326
377	2	8	278
337	2	9	230
297	2	10	182
257	2	11	134
217	2	12	86
177	2	13	38

Trigger interval [H]	FPS	RPS	Effective Lines [H]
617	3	1	566
577	3	2	518
537	3	3	470
497	3	4	422
457	3	5	374
417	3	6	326
377	3	7	278
337	3	8	230
297	3	9	182
257	3	10	134
217	3	11	86
177	3	12	38

Trigger interval [H]	FPS	RPS	Effective Lines [H]
577	4	1	518
537	4	2	470
497	4	3	422
417	4	4	326
417	4	5	326
377	4	6	278
337	4	7	230
257	4	8	134
257	4	9	134
217	4	10	86
177	4	11	38

Trigger interval [H]	FPS	RPS	Effective Lines [H]
537	5	1	470
497	5	2	422
457	5	3	374
417	5	4	326
377	5	5	278
337	5	6	230
297	5	7	182
257	5	8	134
217	5	9	86
177	5	10	38

Trigger interval [H]	FPS	RPS	Effective Lines [H]
497	6	1	422
457	6	2	374
417	6	3	326
377	6	4	278
337	6	5	230
297	6	6	182
257	6	7	134
217	6	8	86
177	6	9	38

Trigger interval [H]	FPS	RPS	Effective Lines [H]
457	7	1	374
417	7	2	326
377	7	3	278
337	7	4	230
297	7	5	182
257	7	6	134
217	7	7	86
177	7	8	38

Trigger interval [H]	FPS	RPS	Effective Lines [H]
417	8	1	326
377	8	2	278
337	8	3	230
297	8	4	182
257	8	5	134
217	8	6	86
177	8	7	38

Trigger interval [H]	FPS	RPS	Effective Lines [H]
377	9	1	278
337	9	2	230
297	9	3	182
257	9	4	134
217	9	5	86
177	9	6	38

Trigger interval [H]	FPS	RPS	Effective Lines [H]
337	10	1	230
297	10	2	182
257	10	3	134
217	10	4	86
177	10	5	38

Trigger interval [H]	FPS	RPS	Effective Lines [H]
297	11	1	182
257	11	2	134
217	11	3	86
177	11	4	38

Trigger interval [H]	FPS	RPS	Effective Lines [H]
257	12	1	134
217	12	2	86
177	12	3	38

Trigger interval [H]	FPS	RPS	Effective Lines [H]
217	13	1	86
177	13	2	38

Trigger interval [H]	FPS	RPS	Effective Lines [H]
177	14	1	38

Trigger interval [H]	FPS	RPS	Effective Lines [H]
791	0	0	768

Notes

- Frame rate is equal to the trigger interval in the settings indicated above. (This is the highest frame rate.)
- The settings indicated above apply to the settings of slow to middle shutter speeds while using the Overlap function.
- The setting of FPS: 4 and RPS: 4 is the same as setting FPS: 4 and RPS: 5.
- The setting of FPS: 4 and RPS: 8 is the same as setting FPS: 4 and RPS: 9.

Input/Output Signal Specifications

External-HD/VD input phase specifications

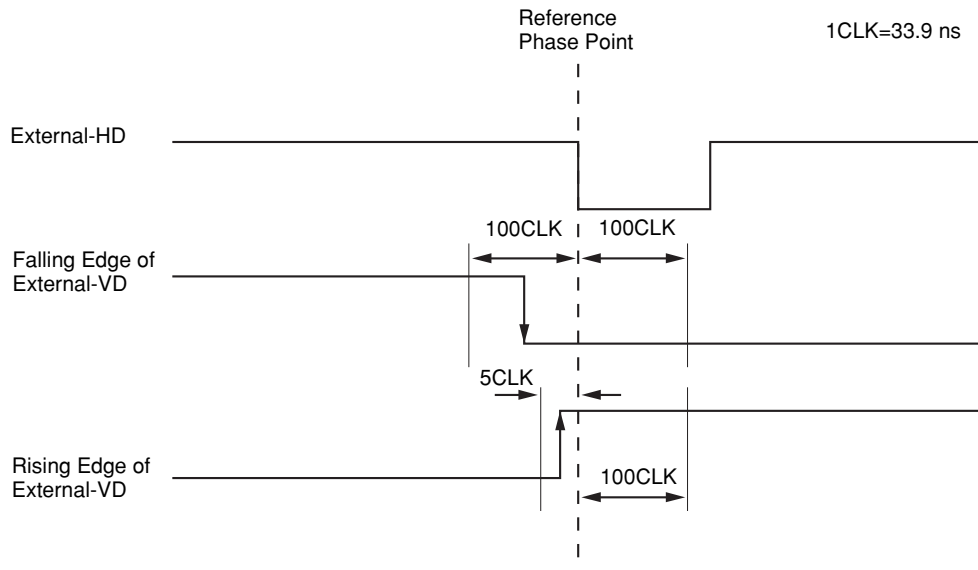

Input External-HD/VD signals that meet the specifications indicated above.

Falling edge of External-VD:

Input the falling edge of External-VD signals within 100 CLK earlier or later, with the falling edge of the External-HD signals as a reference.

These input phase specifications apply to all Camera Modes except for Trigger Mode2.

Rising edge of External-VD:

Input the rising edge of the External-VD signals within 5 CLK earlier or 100 CLK later, with the falling edge of External-HD signals as a reference.

These input phase specifications apply to High-rate scan I in Restart/Reset Mode.

Notes

- The falling edges of Internal-HD/VD signals fall in neatly with the falling edges of External-HD signals. LVAL/FVAL signals are output 11 CLK later, with the falling edges of External-HD signals as a reference. FVAL signals are output 1H later than that for External-HD signals when operating in all Camera Modes with external synchronization.
- Be aware that the camera module automatically detects external synchronization only when External-HD signals meeting the input specifications are input.
- The input phase specifications above apply to both the 12-pin connector and the digital interface connector.

■ External-HD Input Specifications

DC IN connector

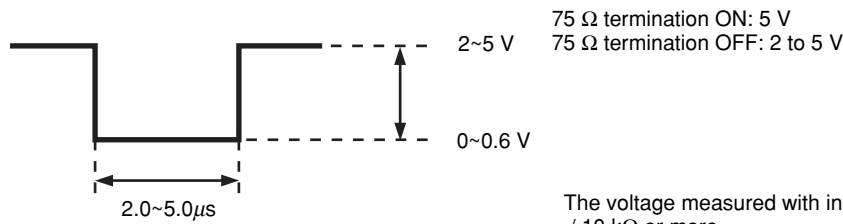

The voltage measured with input impedance of 75 Ω / 10 k Ω or more

DIGITAL IF connector

Input signals meeting the input specifications above converted to the signal level of the LVDS system (output by the 3.3 V IC). Be aware that if the signals fail to meet the following conditions, the camera module will not recognize the input signals properly.

H level: 1.5 V to 1.7 V

L level: 0.8 V to 1.0 V

■ External-VD Input Specifications

DC IN connector

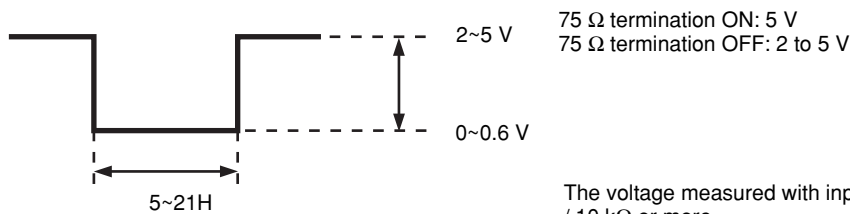

The voltage measured with input impedance of 75 Ω / 10 k Ω or more

DIGITAL IF connector

Input signals meeting the input specifications above converted to the signal level of the LVDS system (output by the 3.3 V IC). Be aware that if the signals fail to meet the following conditions, the camera module will not recognize the input signals properly.

H level: 1.5 V to 1.7 V

L level: 0.8 V to 1.0 V

■ HD/VD Output Specifications (only for the DC IN connector)



The voltage measured when terminated with 10 k Ω or more

■ Trigger Pulse Specifications

DC IN connector

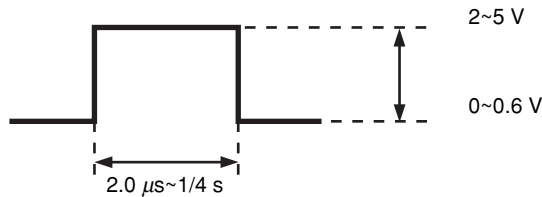

The voltage measured when the input impedance is 10 kΩ or more

DIGITAL IF connector

Input signals meeting the input specifications above converted to the signal level of the LVDS system (output by the 3.3 V IC). Be aware that if the signals fail to meet the following conditions, the camera module will not recognize the input signals properly.

H level: 1.5 V to 1.7 V

L level: 0.8 V to 1.0 V

■ WEN Output Specifications (only for the DC IN connector)



The voltage measured when terminated with 10 kΩ or more

Outputs WEN signals synchronized with the falling edge of Internal-VD, corresponding to the start of video signal output in Trigger Mode1/2.

■ DVAL/LVAL/FVAL Output Specifications (only for the DIGITAL IF connector)

Outputs Camera Link-compatible signals.

H level: approx. 1.5 V

L level: approx. 1.0 V

(When terminated with the specified register)

The following signals are output as enable signals.

DVAL: High (fixed)

LVAL: Horizontal blanking signals (HBLKG)

FVAL: Vertical blanking signals (VBLKG)

Outputs VAL signals for FVAL while using the High-rate scan II function.

VAL: While using High-rate scan II

Effective image interval: High

BLKG interval: Low

■ External-CLK Specifications (common to the DC IN /DIGITAL IF connectors)

Supports LVDS input signals for both types of connectors.

Specifications for the External-CLK input are as follows.

CLK-Duty: 50%

The range of input clock signal frequency: 29.5 to 59 MHz

Input signals meeting the input specifications above converted to the signal level of the LVDS system (output by the 3.3 V IC). Be aware that if the signals fail to meet the following conditions, the camera module will not recognize the input signals properly.

H level: 1.5 V to 1.7 V

L level: 0.8 V to 1.0 V

Notes

- Input the external input signals after the power is turned on. If you input external input signals before the power is turned on, this may result in a malfunction of the camera module. This applies for External-clock/HD/VD and the trigger pulse.
- When using external clock signals, be sure to input continuous external clock signals, and then enter the EXTHVCLK (External HD/VD/CLK signal input Selection) command that specifies an input path for external clock signals before entering the CLKSEL (Master Clock Selection) command. Select an input path for external clock signals first, and then enter the CLKSEL (Master Clock Selection) command. When changing an input path for external clock signals as well, change the clock setting from external clock to normal internal clock signals first, and then change the clock setting again to external clock signals observing the condition above. Be aware that if this condition is not observed, the camera module may stop the operation. When changing the clock setting from external clock to normal internal clock signals, stop inputting external clock signals after the clock mode has changed to the internal clock mode completely. Be sure to start the operation by external clock signals observing the condition above. Be aware that if this condition is not observed, the camera module may stop the operation.
- When using external clock synchronization, input External-HD signals with a 1270 count interval derived from an external clock with frequency division for the external-HD signals. Be aware that if this condition is not observed, both horizontal sync signals and video output signals stop.

CCD Output Waveform Timing Chart

• Horizontal Output Waveform Timing Chartt (1CLK = 39.9 ns)

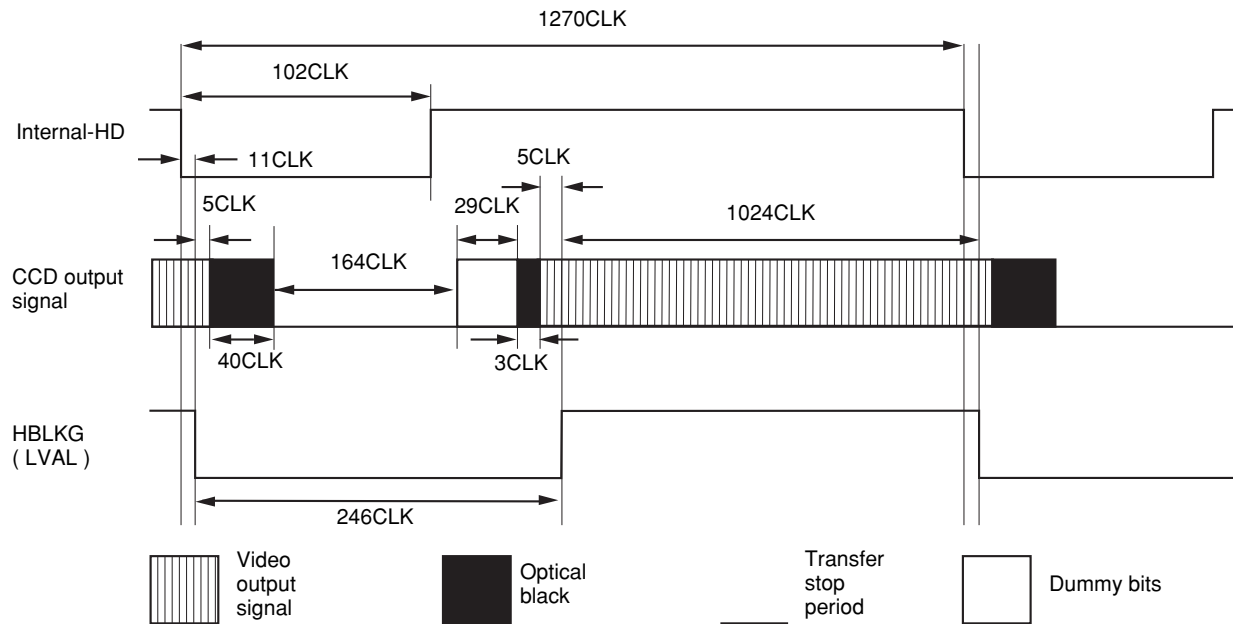

• Vertical Output Waveform Timing Chart

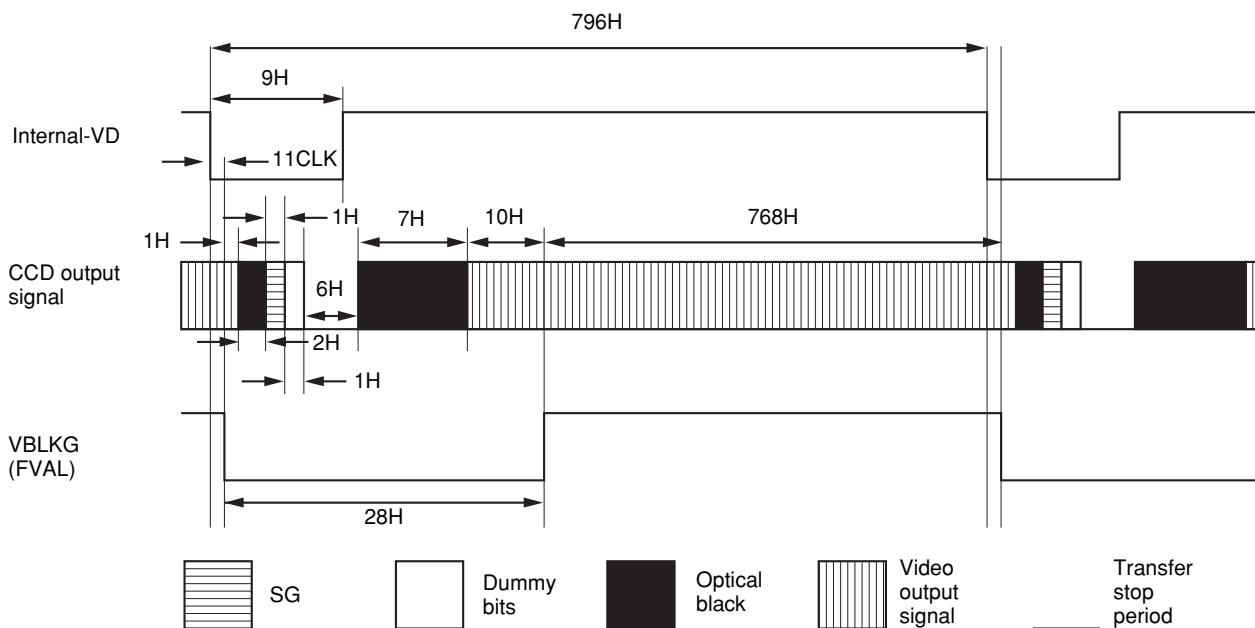

Note

Some interface boards for the camera (frame grabber) may not obtain up to 768 H. In this situation, reduce 1 to 3H of vertical area to be obtained.

Functions of the XCL-V500

About the Camera Modes

■ Normal Mode (when operating in external synchronization)

Description: Outputs each independent pixel video signal for 1/60 second. Internal or external synchronization is recommended.

standard video output.

Application: Use this mode to provides continuous

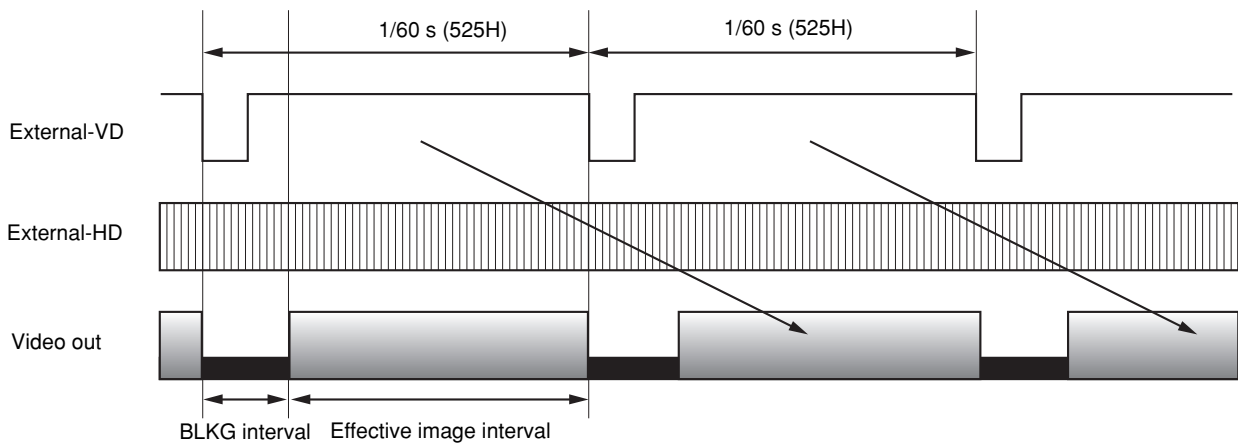

■ Restart/ Reset mode (when operating in external synchronization)

Description: Outputs each independent pixel video signal of a single shot for which exposure time is proportional to the interval of External-VD signals, synchronized with External-VD signals. External synchronization is recommended.

satisfactory sensitivity in the Normal Mode, or when you want to observe the trail of a moving object.

Application: Use this mode when you cannot gain

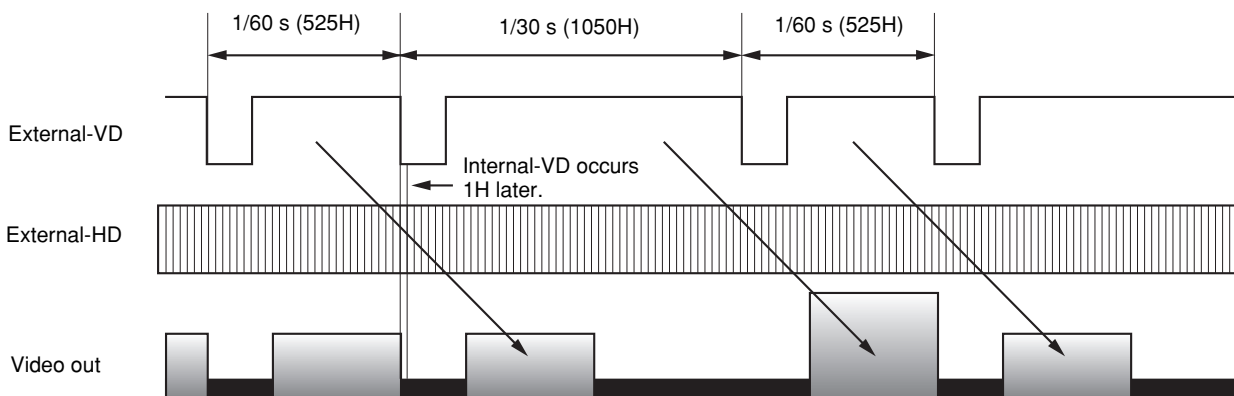

■ Trigger Mode1 (when operating in external synchronization with the shutter operation controlled by a trigger pulse width)

Description: Controls the shutter synchronized with externally input trigger signals and outputs each independent pixel video signal of a single shot synchronized with External-VD signals. External synchronization is recommended. We recommend that external trigger signals, External-VD signals, and External-HD signals are all synchronized with each other, and the ratio of the external trigger

signals and the External-VD signals should be 1:1. When you use the fixed speed trigger shutter, input the External-VD signals synchronized to the output.

Application: Use this mode to capture fast-moving objects in a precise position synchronized with External-VD signals because in this mode, the shutter is controlled by inputting external trigger signals.

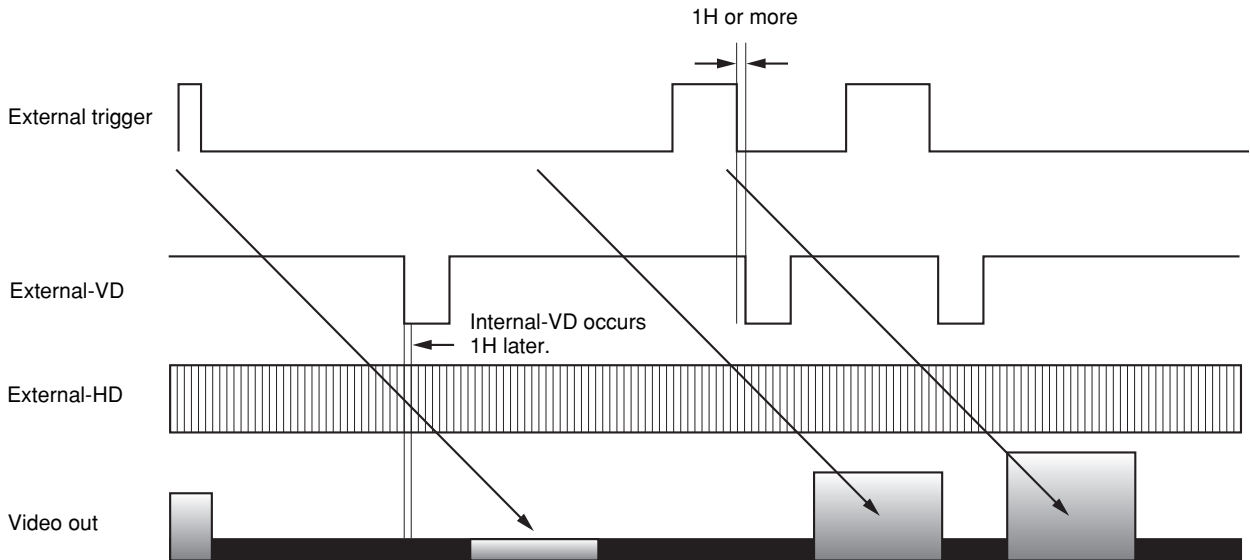

■ Trigger Mode2 (when operating in internal synchronization with the shutter operation controlled by a trigger pulse width)

Description: Controls the shutter synchronized with externally input trigger signals and outputs each independent pixel video signal of a single shot in synchronization with externally input trigger signals after a certain period. Internal or external synchronization is recommended.

Application: Use this mode to obtain video output synchronized with externally input trigger signals after a certain period without inputting External-VD signals as in case of the Trigger Mode1.

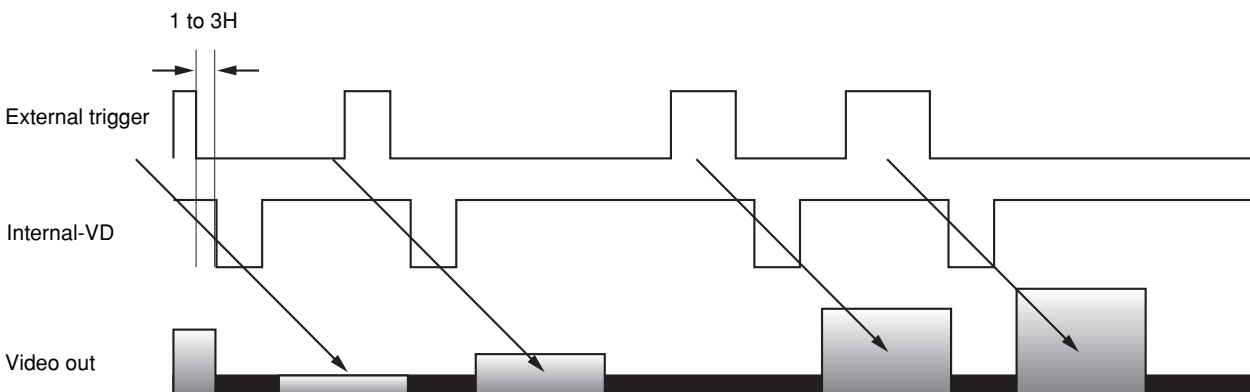

About the Camera Functions

■ Electronic Shutter Function

Normal Shutter

The electronic shutter is used for continuous video output to capture fast-moving objects clearly. Shutter speeds of 1, 1/100, 1/125, 1/250, 1/500, 1/1000, 1/2000, 1/4000, 1/10000, 1/15000, 1/30000 second are supported. Normal Mode is supported for the Camera Mode.

External Trigger Shutter

The electronic shutter is used synchronized with externally input trigger signals to capture fast-moving objects clearly and in a precise position. There are two types of external trigger shutter: an external trigger shutter controlled by external input trigger pulse width and a fixed speed external trigger shutter synchronized with the timing of an externally input trigger. Trigger Mode1 and Trigger Mode 2 are both supported for the Camera Mode.

- **Fixed external trigger shutter speeds:**

1, 1/100, 1/125, 1/250, 1/500, 1/1000, 1/2000, 1/4000, 1/10000, 1/25000, 1/50000, 1/100000 second are supported.

- **External trigger shutter speed is controlled by external trigger pulse width:**

You can obtain an arbitrary shutter speed by setting the external trigger pulse width to the range of 2 μsec to 1/4 sec.

- When trigger signals are input through the 12-pin connector

External trigger pulse width shutter speed = external trigger pulse width + 6 μsec

- When trigger signals are input through the DIGITAL IF connector

External trigger pulse width shutter speed = external trigger pulse width + 5 μsec

■ Overlap Function

One way to increase frame rate while using slow to mid-speed trigger pulse width shutter in the case of previous analog cameras ① is to input the rising edge of the external trigger signals during the effective image interval as indicated in case ②. Noise is generated when the rising edge of the external trigger signal is input during the effective image interval, however, and the effective video output deteriorates and becomes unusable. As a consequence, we must input the signal after the effective image interval and we cannot increase frame rate indicated as T2 in the case of ②. The frame rate results in:

T1 = approx. Effective image interval + exposure time
 T2 = approx. Effective image interval

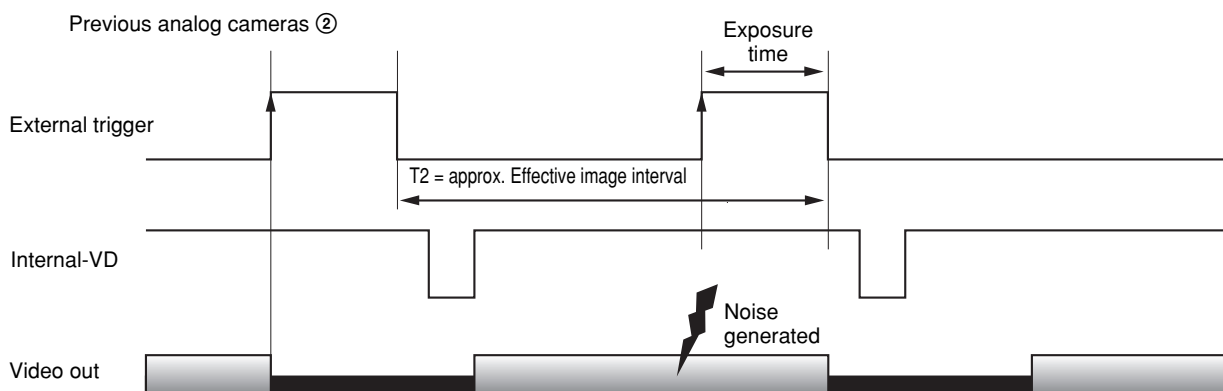
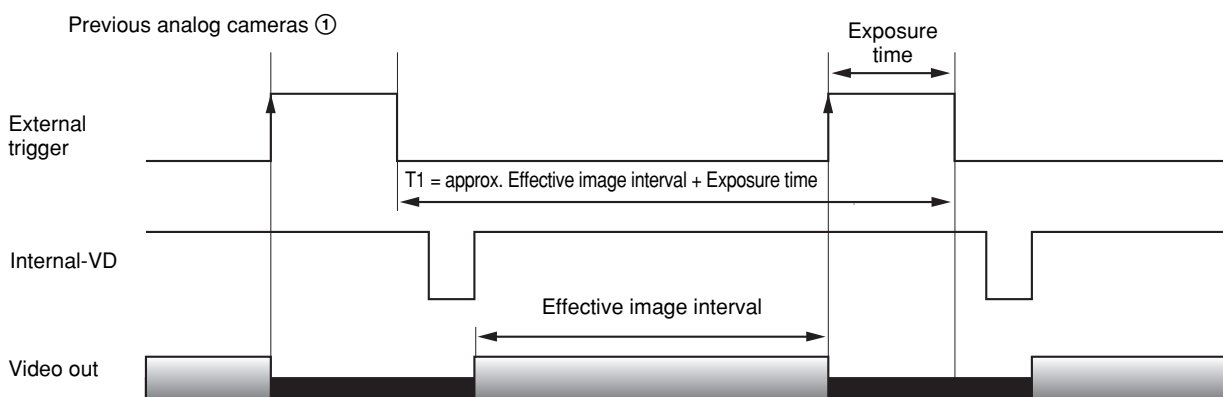

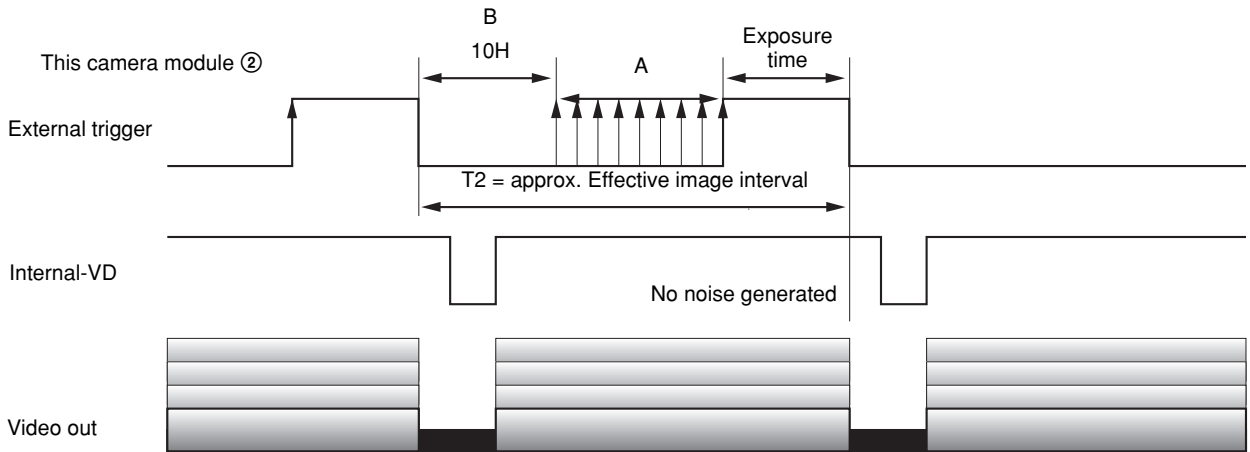
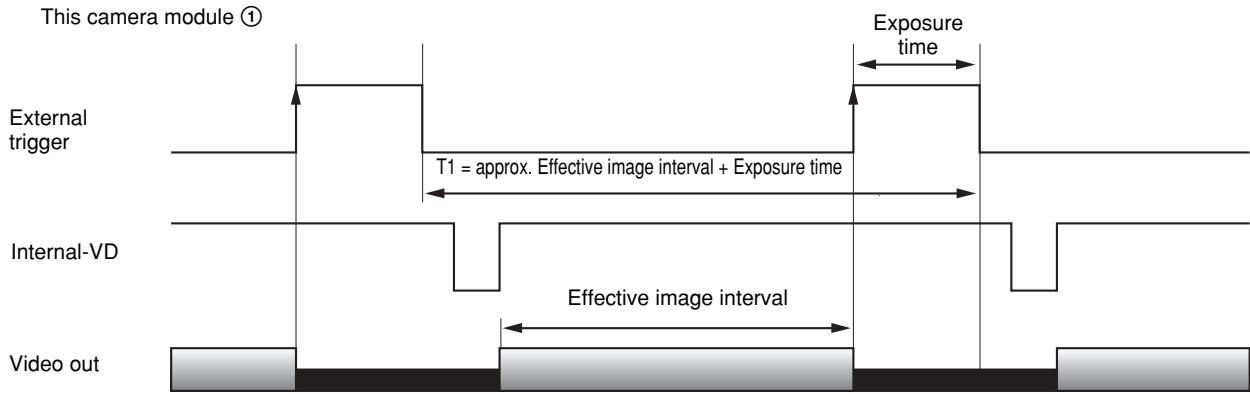

This camera is equipped with an Overlap function which eliminates the effect of noise accompanying the increase of frame rate while using a slow to mid-speed shutter. This camera module can be used in the operation mode that can increase frame rate without noise generation as indicated in ② as well as that in ① that is equal to the operation of previous analog cameras. Thanks to this function, exposure time can be prolonged, and shutter speed can be slowed down, keeping a high frame rate by putting the rising edge of the external trigger earlier as indicated by A in ②. Be aware that the maximum interval in which you can input the rising edge of the external trigger is in the range of 10 H after the falling edge of the previous trigger to the rising edge of the next trigger as indicated by B in ②. Trigger Mode1 and 2 are supported for the Camera Mode.

Notes

- The description above is the operation while using a slow to mid-speed shutter controlled by the external trigger pulse width. When using a fixed speed external trigger shutter, be sure to input the rising edge of the next trigger after the internal exposure time and at the appropriate timing so as not to affect the effective image interval corresponding to the current trigger signal. Be aware that if this condition is not observed, the following may occur.
 - To which frames the effective images corresponding to the external trigger signals will be output may be inconsistent.
 - Double exposure
 - Signals in the blanking interval may be output in the effective image interval.
- If you change settings such as Camera Mode while using the Overlap function, video output may be disturbed.
- A deviation of a maximum about 1H is generated for the exposure time by the Overlap function, so the supported shutter speeds are limited to those for which this exposure deviation can be ignored.

External Clock Input Function

Previously, the operating speed of a camera was fixed. This camera can change its operating speed from the normal speed to half of that.

By utilizing the external clock input function, clock jitter is completely eliminated.

All modes are supported for the Camera Mode.

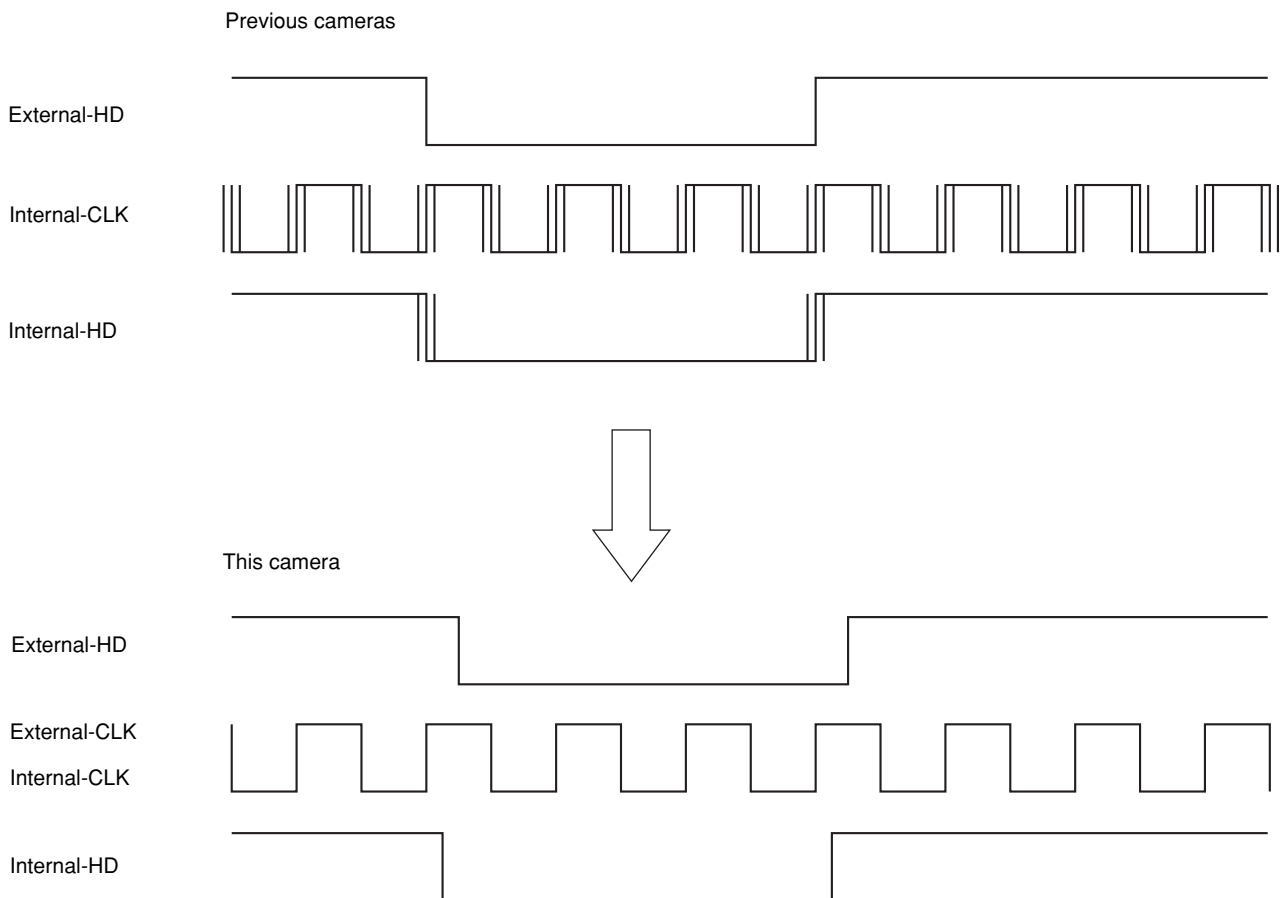

Notes

- Be aware that the shift of phase occurs in the range of $-2 \times \text{CLK}$ to 0 (reference: External-CLK) for Internal-HD signals depending on the timing when the power is turned on. The amount of the shift is not always the same and varies within the range described above every time the power is turned on.
- Be aware that noise is generated when the Internal/ External clock is switched.

The speed of the electronic shutter is determined by the frequency of the external input clock signals. Calculate the shutter speed according to the following formula.

Normal shutter speed:

$$\text{Exposure time} = \{ 685 \times A + 95 \times (A-1) + 187 \} \times 2/\text{ECLK}$$

$$\text{Shutter speed} = 1/\text{Exposure time}$$

A:	1	(1/30000 s)
	2	(1/15000 s)
	3	(1/10000 s)
	8	(1/4000 s)
	16	(1/2000 s)
	31	(1/1000 s)
	63	(1/500 s)
	126	(1/250 s)
	251	(1/125 s)
	314	(1/100 s)

ECLK: External clock frequency: 49.09090 (MAX) to 24.54545 (MIN) MHz

Fixed external trigger shutter speeds:

$$\text{Exposure time} = \{ A + B \times 780 + 144 \} \times 2/\text{ECLK}$$

$$\text{Shutter speed} = 1/\text{Exposure time}$$

A:	101	B:	0	(1/100000 s)
	347		0	(1/50000 s)
	838		0	(1/25000 s)
	2311		0	(1/10000 s)
	5992		0	(1/4000 s)
	12129		0	(1/2000 s)
	0		31	(1/1000 s)
	0		63	(1/500 s)
	0		126	(1/250 s)
	0		252	(1/125 s)
	0		315	(1/100 s)

External trigger pulse width shutter speed:

- When trigger signals are input through the 12-pin connector

$$\text{Exposure time} = \{ \text{external trigger pulse width} + 1 \mu\text{s} \} + 144 \times 2/\text{ECLK}$$

- When trigger signals are input through the DIGITAL IF connector

$$\text{Exposure time} = \{ \text{external trigger pulse width} \} + 144 \times 2/\text{ECLK}$$

$$\text{Shutter speed} = 1/\text{Exposure time}$$

Be aware that the external trigger pulse width should be set in the range of 3 μsec to 1/4 sec when inputting external clock signals.

■ Binning Function

Mixed signals for vertically adjacent pixels of the output of the CCD are output in this function and sensitivity and frame rate are approximately doubled. When the Normal shutter is OFF in the Normal Mode, the frame rate is doubled but exposure time is halved, so that the effect of this function is cancelled out as in the Reset/Restart mode. Both sensitivity and frame rate are doubled when the Normal shutter is ON (1/100 s is not supported).

All modes are supported for the Camera Mode. But High-rate scan II in Trigger Mode2 is not supported.

■ High-rate scan I Function

You can transfer less critical portions of the image except for the important center section of the effective image at high frame rates and obtain image output at high frame rates. This function can be controlled by manipulating the setting of the low width of the External-VD signals and the trigger interval (You also

need to make the external trigger interval setting for Trigger Mode1.)

Only Restart/Reset mode and Trigger Mode1 are supported for the Camera Mode. Only the external trigger pulse width shutter is supported for the electronic shutter.

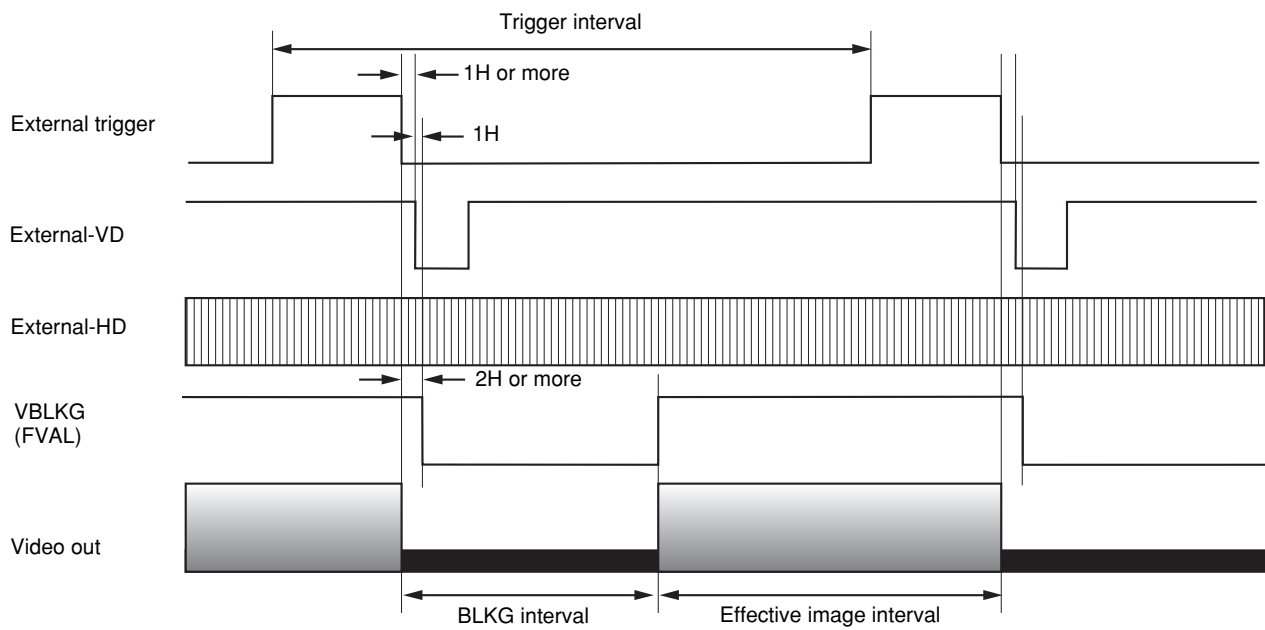
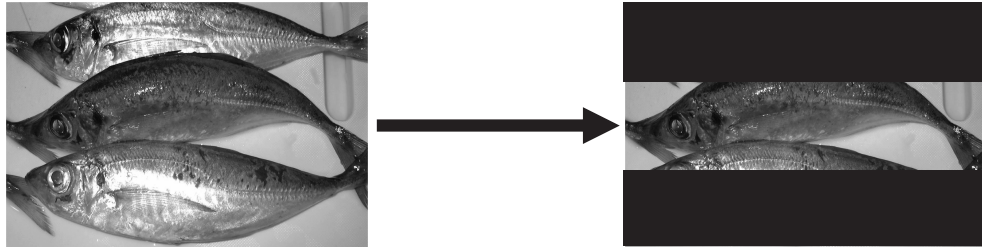

Settings for High-rate scan I

Shaded items are items to be set by the user, after which the following effective lines and frame rates can be obtained.

Restart/Reset Mode Binning: OFF

External-VD interval [H]	External-VD width [H]	BLKG width [H]	Effective Lines [H]
525	High-rate scan I: OFF	20	494
262	12	23	239
175	16	27	148
131	17	28	103

Restart/Reset Mode Binning: ON

External-VD interval [H]	External-VD width [H]	BLKG width [H]	Effective Lines [H]
263	High-rate scan I: OFF	20	240
175	9	20	155
131	13	24	107

Trigger Mode1 Binning: OFF

Trigger interval [H]	External-VD width [H]	BLKG width [H]	Effective Lines [H]
525	High-rate scan I: OFF	20	494
262	12	23	237
175	16	27	146
131	17	28	101

Trigger Mode1 Binning: ON

Trigger interval [H]	External-VD width [H]	BLKG width [H]	Effective Lines [H]
263	High-rate scan I: OFF	20	240
175	9	20	153
131	13	24	105

Notes

- Frame rate is equal to the External-VD/Trigger interval in the settings indicated above. (This is the highest frame rate.)
- The settings for Trigger Mode1 indicated above apply to the setting of slow to middle shutter speeds while using the Overlap function. For middle to high shutter speeds, follow the settings for High-rate scan II (See page 36 and 37) for External-VD/trigger signals. While in Restart/Reset Mode, the shutter speed is fixed in accordance with the External-VD interval.
- The timing chart indicated on the previous page shows the case of Trigger Mode1. For Restart/ Reset mode, trigger input is ignored.

■ High-rate scan II Function

You can divide the effective image interval vertically into 16 sections and select arbitrary sections as the effective image. You can transfer less critical sections at high frame rates and obtain image output at high frame rates. The frame rate and less critical sections are set by the external trigger input interval and then inputting a command. Necessary sections

corresponding to the effective image interval and less critical sections to be transferred at high frame rates are designated and controlled by FPS/RPS settings. Only Trigger Mode2 is supported for the Camera Mode. Only the external trigger pulse width shutter is supported for the electronic shutter.

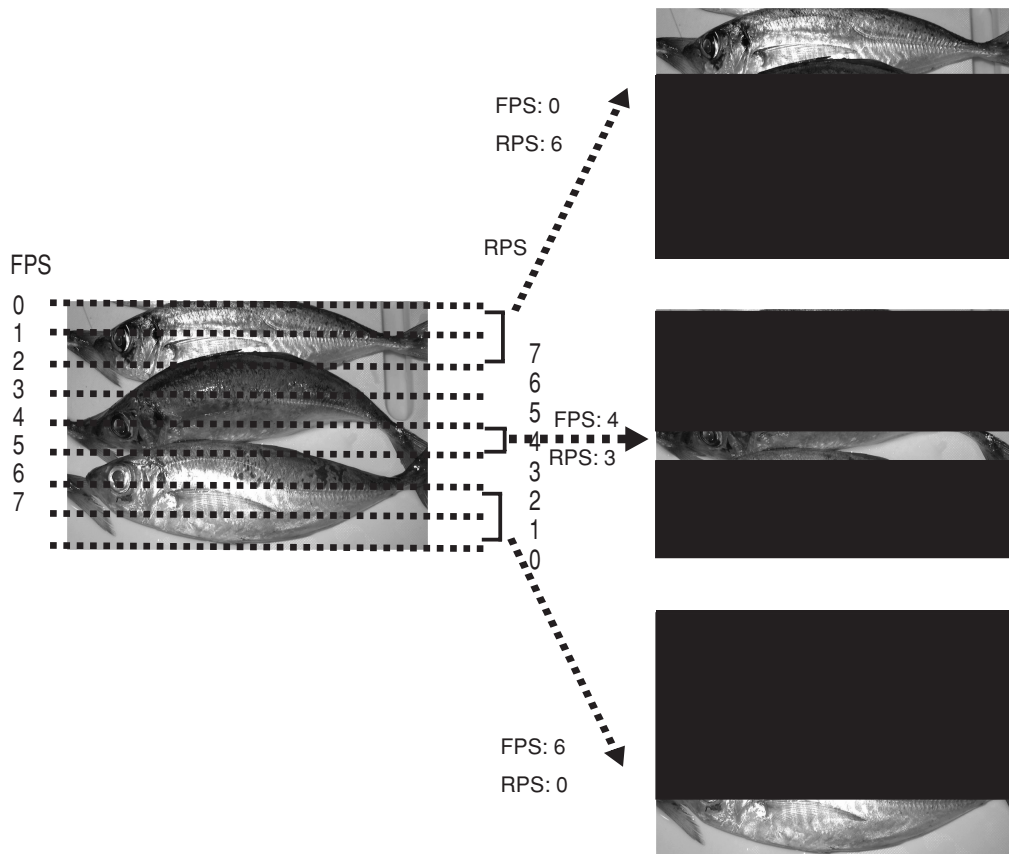

Timing Chart for High-rate scan II while using the Overlap function (slow to mid-speed shutter)

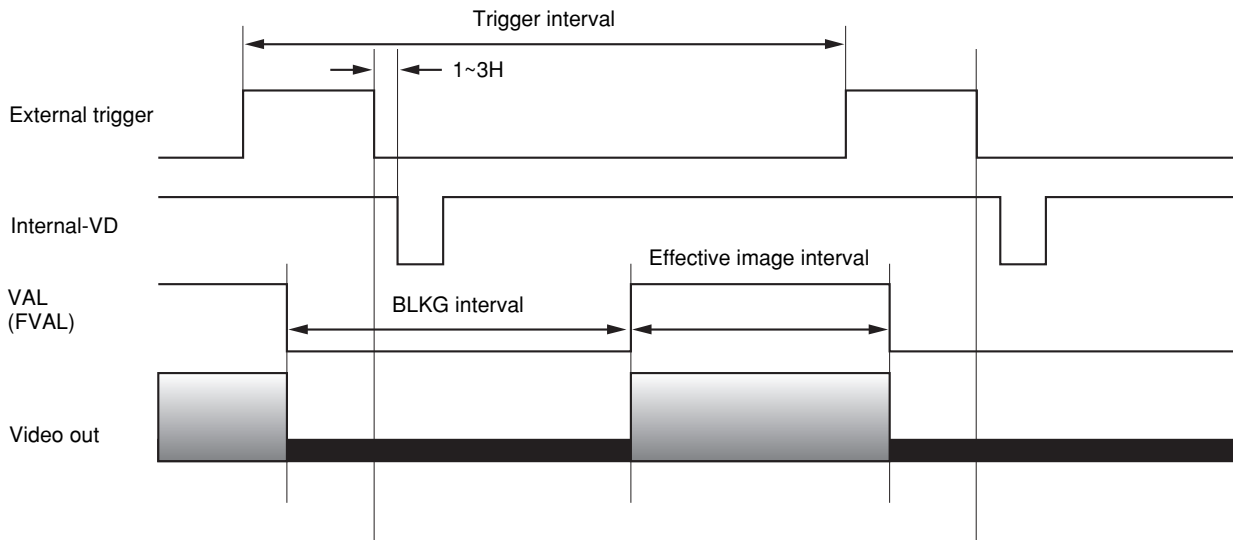

Timing Chart for High-rate scan II while using the Overlap function (middle to high speed shutter)

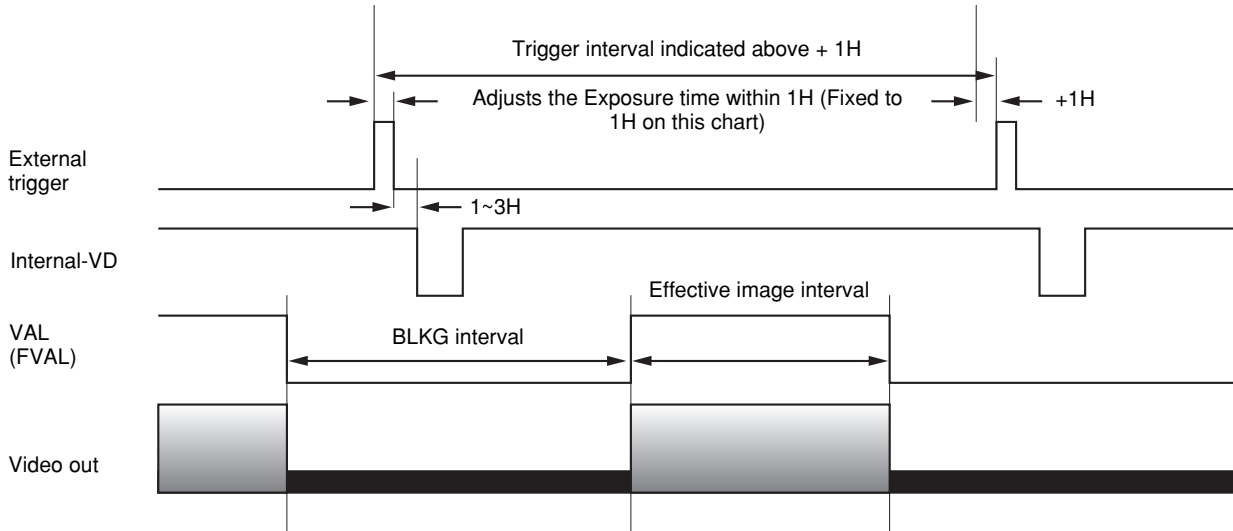

The settings for High-rate scan II on the following page apply to the setting of slow to middle shutter speeds controlled by the external trigger pulse width while using the Overlap function. When using middle to high speed shutter speeds, input the external trigger setting value of the external trigger interval on the following page + 1H without using the Overlap function as indicated in the timing chart above. The timing chart above shows the case when the exposure time is set to less than 1H. (Change trigger pulse width

in accordance with exposure time.) When you want to increase exposure time to 2H or more, increase the external trigger interval 1H by 1H, for example, to +2H, +3H... in accordance with the desired exposure time. Be aware that frame rate is decreased in such a setting.

Settings for High-rate scan II

Shaded items are the items to be set by the user, after which the following effective lines and frame rates can be obtained.

Trigger interval [H]	FPS	RPS	Effective Lines [H]
452	1	0	424
402	2	0	364
352	3	0	304
302	4	0	244
252	5	0	184
202	6	0	124
152	7	0	64

Trigger interval [H]	FPS	RPS	Effective Lines [H]
451	0	1	420
401	0	2	360
351	0	3	300
301	0	4	240
251	0	5	180
201	0	6	120
151	0	7	60

Trigger interval [H]	FPS	RPS	Effective Lines [H]
391	1	1	350
341	1	2	290
291	1	3	230
241	1	4	170
191	1	5	110
141	1	6	50

Trigger interval [H]	FPS	RPS	Effective Lines [H]
341	2	1	290
291	2	2	230
241	2	3	170
191	2	4	110
141	2	5	50

Trigger interval [H]	FPS	RPS	Effective Lines [H]
291	3	1	230
241	3	2	170
191	3	3	110
141	3	4	50

Trigger interval [H]	FPS	RPS	Effective Lines [H]
241	3	1	170
191	3	2	110
141	3	3	50

Trigger interval [H]	FPS	RPS	Effective Lines [H]
191	4	1	110
141	4	2	50

Trigger interval [H]	FPS	RPS	Effective Lines [H]
141	4	2	50

Trigger interval [H]	FPS	RPS	Effective Lines [H]
512	0	0	494

Notes

- Frame rate is equal to the trigger interval in the settings indicated above. (This is the highest frame rate.)
- The settings indicated above apply to the settings of slow to middle shutter speeds while using the Overlap function.

Input/Output Signal Specifications

External-HD/VD input phase specifications

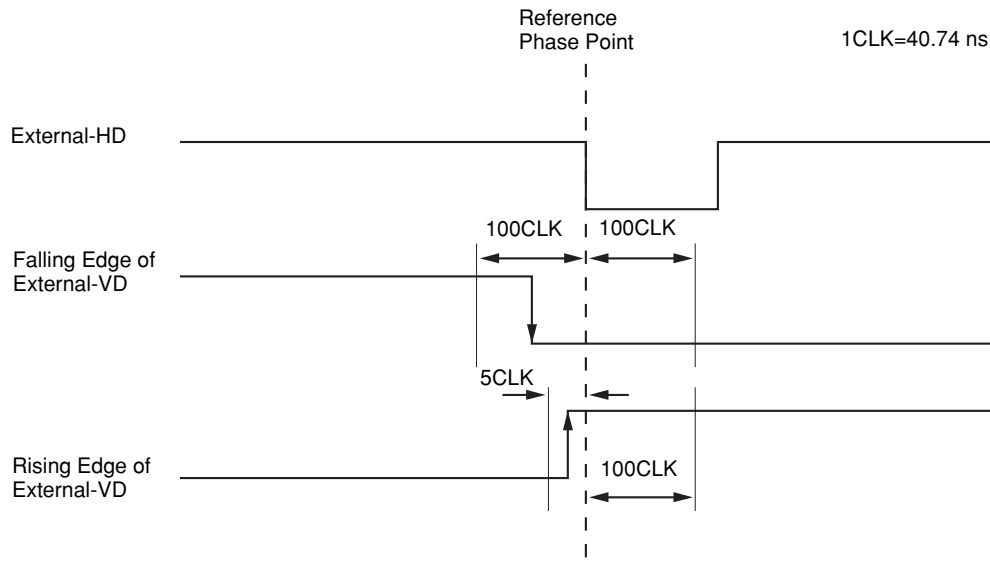

Input External-HD/VD signals that meet the specifications indicated above.

Falling edge of External-VD:

Input the falling edge of External-VD signals within 100 CLK earlier or later, with the falling edge of the External-HD signals as a reference.

These input phase specifications apply to all Camera Modes except for Trigger Mode2.

Rising edge of External-VD:

Input the rising edge of the External-VD signals within 5 CLK earlier or 100 CLK later, with the falling edge of External-HD signals as a reference.

These input phase specifications apply to High-rate scan I in Restart/Reset Mode.

Notes

- The falling edges of Internal-HD/VD signals fall in neatly with the falling edges of External-HD signals. LVAL/FVAL signals are output 11 CLK later, with the falling edges of External-HD signals as a reference. FVAL signals are output 1H later than that for External-HD signals in Restart/Reset Mode and Trigger Mode1.
- Be aware that the camera module automatically detects external synchronization only when External-HD signals meeting the input specifications are input.
- The input phase specifications above apply to both the 12-pin connector and the digital interface connector.
- To operate the camera module in the Normal Mode with external synchronization, input External-VD signals with a 525H interval.
To operate the camera module in the Normal Mode with external synchronization with the Binning function on, input External-VD signals with a 263H interval.

External-HD Input Specifications

DC IN connector

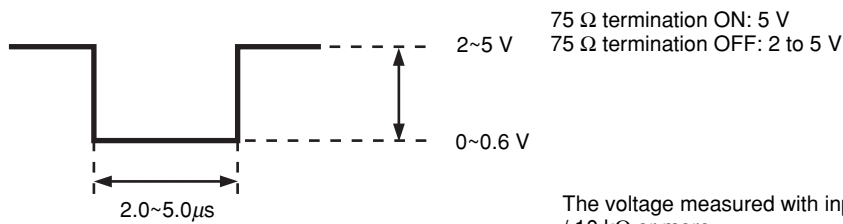

DIGITAL IF connector

Input signals meeting the input specifications above converted to the signal level of the LVDS system (output by the 3.3 V IC). Be aware that if the signals fail to meet the following conditions, the camera module will not recognize the input signals properly.

H level: 1.5 V to 1.7 V

L level: 0.8 V to 1.0 V

External-VD Input Specifications

DC IN connector

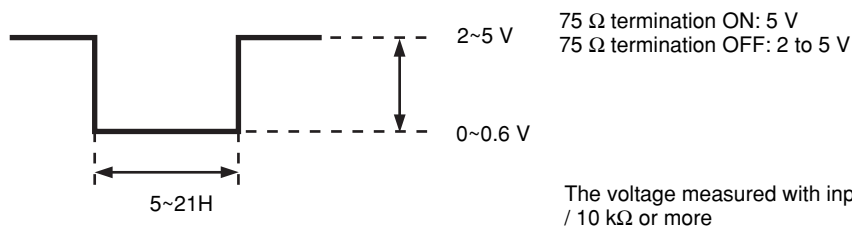

DIGITAL IF connector

Input signals meeting the input specifications above converted to the signal level of the LVDS system (output by the 3.3 V IC). Be aware that if the signals fail to meet the following conditions, the camera module will not recognize the input signals properly.

H level: 1.5 V to 1.7 V

L level: 0.8 V to 1.0 V

HD/VD Output Specifications (only for the DC IN connector)

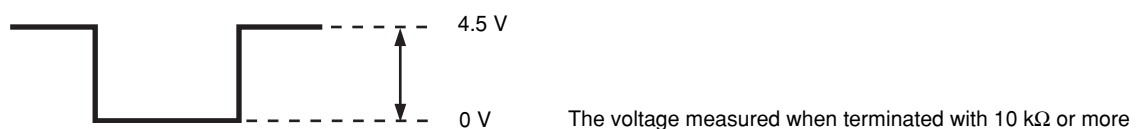

■ Trigger Pulse Specifications

DC IN connector

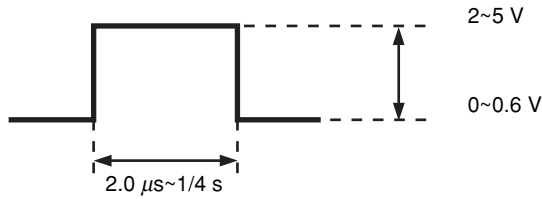

The voltage measured when the input impedance is 10 kΩ or more

DIGITAL IF connector

Input signals meeting the input specifications above converted to the signal level of the LVDS system (output by the 3.3 V IC). Be aware that if the signals fail to meet the following conditions, the camera module will not recognize the input signals properly.

H level: 1.5 V to 1.7 V

L level: 0.8 V to 1.0 V

■ WEN Output Specifications (only for the DC IN connector)



The voltage measured when terminated with 10 kΩ or more

Outputs WEN signals synchronized with the falling edge of Internal-VD, corresponding to the start of video signal output in Trigger Mode1/2.

■ LVAL/FVAL Output Specifications (only for the DIGITAL IF connector)

Outputs Camera Link-compatible signals.

H level: approx. 1.5 V

L level: approx. 1.0 V

(When terminated with the specified register)

The following signals are output as enable signals.

DVAL: High (fixed)

LVAL: Horizontal blanking signals (HBLKG)

FVAL: Vertical blanking signals (VBLKG)

Outputs VAL signals for FVAL while using the High-rate scan II function.

VAL: While using High-rate scan II

Effective image interval: High

BLKG interval: Low

■ External-CLK Specifications (common to the DC IN /DIGITAL IF connectors)

Supports LVDS input signals for both types of connectors.

Specifications for the External-CLK input are as follows.

CLK-Duty: 50%

The range of input clock signal frequency: 29.5 to 59 MHz

Input signals meeting the input specifications above converted to the signal level of the LVDS system (output by the 3.3 V IC). Be aware that if the signals fail to meet the following conditions, the camera module will not recognize the input signals properly.

H level: 1.5 V to 1.7 V

L level: 0.8 V to 1.0 V

Notes

- Input the external input signals after the power is turned on. If you input external input signals before the power is turned on, this may result in a malfunction of the camera module. This applies for External-clock/HD/VD and the trigger pulse.
- When using external clock signals, be sure to input continuous external clock signals, and then enter the EXTHVCLK (External HD/VD/CLK signal input Selection) command that specifies an input path for external clock signals before entering the CLKSEL (Master Clock Selection) command. Select an input path for external clock signals first, and then enter the CLKSEL (Master Clock Selection) command. When changing an input path for external clock signals as well, change the clock setting from external clock to normal internal clock signals first, and then change the clock setting again to external clock signals observing the condition above. Be aware that if this condition is not observed, the camera module may stop the operation. When changing the clock setting from external clock to normal internal clock signals, stop inputting external clock signals after the clock mode has changed to the internal clock mode completely. Be sure to start the operation by external clock signals observing the condition above. Be aware that if this condition is not observed, the camera module may stop the operation.
- When using external clock synchronization, input External-HD signals with a 780 count interval derived from an external clock with frequency division for the external-HD signals. Be aware that if this condition is not observed, both horizontal sync signals and video output signals stop.

CCD Output Waveform Timing Chart

• Horizontal Output Waveform Timing Chart (1CLK = 40.7 ns)

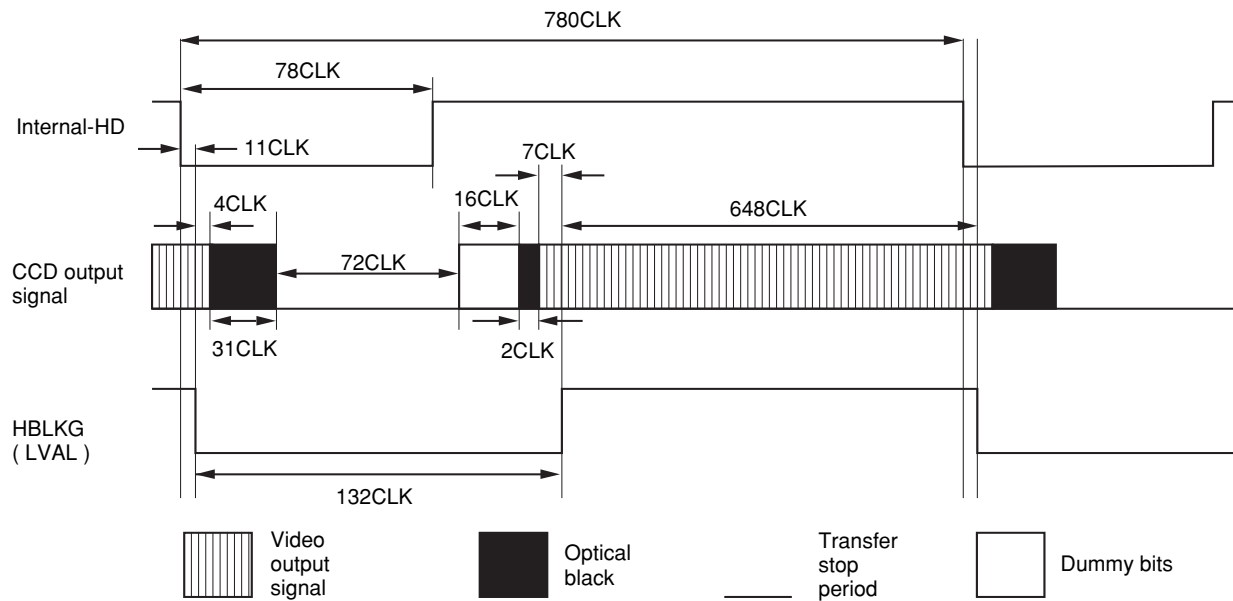

• Vertical Output Waveform Timing Chart

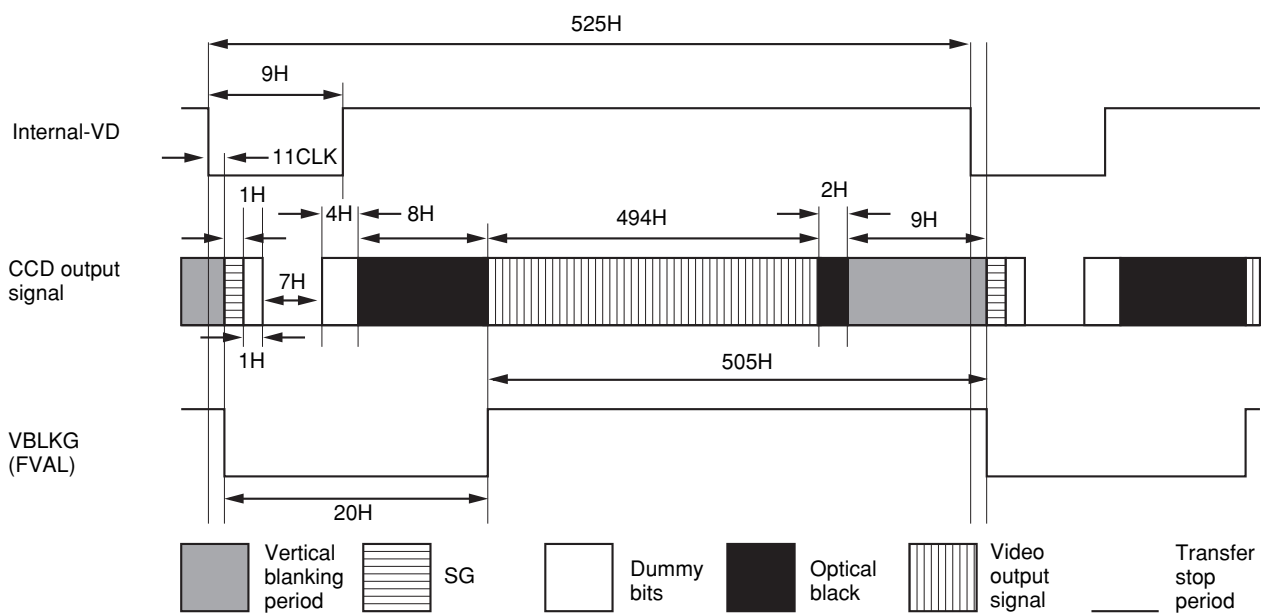

Note

Some interface boards for the camera (frame grabber) may not obtain up to 494 H. In this situation, reduce 1 to 3H of vertical area to be obtained.

Camera Control Command

Overview

The XCL-X700/V500 (Black and White Video Camera Module) can be controlled externally using serial communication.

This serial communication control is carried out using commands sent via the camera's serial link.

At this time, RS-232C has been replaced by RS-644.

Serial Communication Specifications

The serial communication system for the XCL-X700/V500 is an asynchronous method compliant with RS-232C. The following table shows the transmission control specifications.

Command inputs are echoed back.

Baud rate	38400/19200 [bps] Default setting: 38400[bps]
Data bits	8
Parity	None
Stop bit	1
Flow control	None

Command System

The following table shows the command system.

Command category	Description
Camera control commands	Controls the camera.
Setting value control command	Controls setting data saved in the camera.

Command Format

To input (send) a command, delimit a command name and parameters with spaces, and press the Enter (Carriage Return) key.

The following show the input format and an example:

```
<Input format>  command param1 param2 [Enter]
<Input example> PARTIAL 1 <CR>
```

Input characters are case-insensitive.
Use decimal numbers for parameters.

Command Input and Response

When the camera receives commands from the host, it returns a response after each command is processed. Input commands are echoed back.

Note

To input multiple commands continuously, input a command after the previous command returns the response.

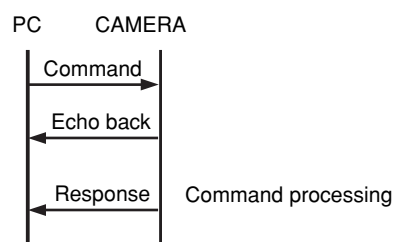

Command response messages are as follows:

```
ok           : normal
error syntax : syntax error
error status  : status error
```

- When command execution is completed normally, the screen displays “ok.”

Example:

```
<Input>          PARTIAL 1 <CR>
<Output on screen> ok <CR/LF>
```

- If command execution is terminated abnormally, the screen displays “error status.”

- When no parameter is input for a command with parameters, the screen displays the current parameters of the command.

Example:

```
<Input>          PARTIAL<CR>
<Output on screen> 1<CR/LF>
```

- If an input value is out of parameter range, the command is invalid and the screen displays “error syntax.”

```
<Input>          PARTIAL 5<CR>
<Output on screen> error syntax<CR/LF>
```

- If an invalid command name is input, the screen displays “error syntax”.

Example:

```
<Input>          PART 1 20<CR>
<Output on screen> error syntax<CR/LF>
```

- If the Enter key is pressed with no command input, only the carriage return is carried out. Any invalid input is ignored.

Command Specifications

This section describes the details of control commands available for the XCL-X700/V500, classified by category.

Camera Control Commands

Camera control commands are classified into five categories. A tab is assigned to each category in camera control applications.

The following table shows the description of each category:

Category	Description
Basic	Sets basic functions (mode/shutter/gain etc.).
Scan	Sets read-out from the CCD.
Partial Scan	Sets High-rate scan (Partial scan).
Pulse	Sets various control pulses.
Comm	Sets RS-232C serial communication.

All parameter values related to the camera control commands are saved in the EEPROM of the camera.

Basic Setting Commands

- Operation Mode Setting

```
[Command]  MODE
[Parameter 1] <Operation Mode (0 to 3)>
0 : NORMAL
1 : Restart/Reset
2 : Trigger Mode 1
3 : Trigger Mode2
[Process]  Sets operation mode.
```

- Shutter Speed Setting

```
[Command]  SHUTTER
[Parameter 1] <Shutter setting (0 to 12)>
```

VGA: normal	XGA: normal	VGA/XGA: trigger
0 : OFF	0 : OFF	0 : OFF
1 : 1/100	1 : 1/100	1 : 1/100
2 : 1/125	2 : 1/125	2 : 1/125
3 : 1/250	3 : 1/250	3 : 1/250
4 : 1/500	4 : 1/500	4 : 1/500
5 : 1/1000	5 : 1/1000	5 : 1/1000
6 : 1/2000	6 : 1/2000	6 : 1/2000
7 : 1/4000	7 : 1/4000	7 : 1/4000
8 : 1/10000	8 : 1/10000	8 : 1/10000
9 : 1/15000	9 : 1/20000	9 : 1/25000
10 : 1/30000	10 : OFF	10 : 1/50000
11 : OFF	11 : OFF	11 : 1/100000
12 : OFF	12 : OFF	12 : Trigger width

[Process] Sets a shutter speed.

■ Gain-Step Setting

[Command] GAIN-STEP
 [Parameter 1] <Gain (0 to 18)> [dB]
 0: 0 dB 8: 8 dB 16: 16 dB
 1: 1 dB 9: 9 dB 17: 17 dB
 2: 2 dB 10: 10 dB 18: 18 dB
 3: 3 dB 11: 11 dB
 4: 4 dB 12: 12 dB
 5: 5 dB 13: 13 dB
 6: 6 dB 14: 14 dB
 7: 7 dB 15: 15 dB
 [Process] Sets the gain value (0 to 18 dB) in 1 dB steps.

■ Gain-Fine Adjustment Setting

[Command] GAIN-FINE
 [Parameter 1] <Gain (0 to 1023)>
 [Process] Fine tunes the gain value.

Scan Setting Commands

■ Binning Mode Setting

[Command] BINNING
 [Parameter 1] <Mode (0 or 1)>
 0: OFF → No binning
 1: V → Vertical binning
 [Process] Selects a binning mode.

Partial Scan Setting Commands

■ High-rate Scan Setting

[Command] PARTIAL
 [Parameter 1] <Mode (0 or 1)>
 0: OFF
 1: Partial Scan (External Control)
 [Process] Selects a high-rate scan (partial scan) mode.

■ PS2 Upper High-Speed Transfer Area Setting

[Command] FPS
 [Parameter 1] <Area (0 to 15(X700)/0 to 7(V500))>
 Sets the area value so that the total sum of the upper area value and the following lower area value does not exceed 15 for the X700 and 7 for the V500.
 [Process] Sets the Upper High-Speed Transfer Areas while performing the Partial Scan II. For details, refer to “Settings for High-rate scan II.” See page 21 for the X700 and page 38 for the V500.

■ PS2 Lower High-Speed Transfer Area Setting

[Command] RPS
 [Parameter 1] <Area (0 to 15(X700)/0 to 7(V500))>
 Sets the area value so that the total sum of the upper area value above and the lower area value does not exceed 15 for the X700 and 7 for the V500.
 [Process] Sets the Lower High-Speed Transfer Areas while performing the Partial Scan II. For details, refer to “Settings for High-rate scan II.” See page 21 for the X700 and page 38 for the V500.

Pulse Setting Commands

■ VD/HD IN/OUT Setting

[Command] VHINTEXT
 [Parameter 1] <IN/OUT (0 or 1)>
 0: VD/HD external (Inputs external synchronous signals)
 1: VD/HD internal (Outputs internal synchronous signals)
 [Process] Sets either input or output for VD/HD signals.

■ External HD/VD/CLK Signal Input Selection Setting

[Command] EXTHVCLK
 [Parameter 1] <Input selection (0 or 1)>
 0: Camera Link → Through the Camera Link connector
 1: DC-700/CE → Through the 12 pin DC connector
 [Process] Specifies an input path for External HD/VD/CLK signals.

■ External Trigger Signal Input Selection

[Command] EXTTRG
 [Parameter 1] <Input selection (0 or 1)>
 0: Camera Link → Through the Camera Link connector
 1: DC-700/CE → Through the 12 pin DC connector
 [Process] Specifies an input path for external trigger signals.

■ Overlap Setting

[Command] TRG-OVLP
 [Parameter 1] <Overlap selection (0 or 1)>
 0: OFF
 1: ON
 [Process] Enables or disables the Overlap function.

■ 75 ohm Termination Setting

[Command] TERM
 [Parameter 1] <Termination (0 or 1)>
 0: ON
 1: OFF
 [Process] Sets 75 ohm termination ON/OFF.

■ Master Clock Select Setting

[Command] CLKSEL
 [Parameter 1] <CLK (0 or 1)>
 0: MASTCK → Internal Clock
 1: EXT_MASTCK → External Clock
 [Process] Selects an internal or external master clock.

COMM Setting Commands

- Serial Communication Speed Setting
 [Command] BRATE
 [Parameter 1] <Baud Rate setting (0 or 1)>
 0: 38400 [bps]
 1: 19200 [bps]
 [Process] Selects a serial communication speed.

Note

This setup becomes effective after the camera is restarted.
 The last setting value input is retained and this item is not initialized, even when an initialization command is executed.

Setting Value Control Commands

Setting value control commands control the camera setting data saved in the EEPROM of the camera. The following table lists the command descriptions. However, the setup of COMM setting commands is outside the scope of control. Even when a particular command is executed, the last setting value is retained and the setting value is not updated:

Command	Description
Initialize Setting	Returns all data related to camera control commands to the factory default values.
Save Setting	Writes all data related to camera control commands into EEPROM.
Read Setting	Reads all data related to camera control commands from EEPROM.
Get Setting Value	Sends data to a camera control application.

Initialize Setting Command

- Setting Initialization
 [Command] INIT
 [Process] Returns all data related to camera control commands to the factory default values. The setup of COMM setting commands (an RS232C communication speed) is outside the scope of control.

Save Setting Command

- Setting Save
 [Command] SAVE
 [Process] Writes all data related to camera control commands to the EEPROM. The setup of COMM setting commands (an RS232C communication speed) is outside the scope of control.

Read Setting Command

- Setting Read
 [Command] LOAD
 [Process] Reads all data related to camera control commands from EEPROM.
 The setup of COMM setting commands (an RS232C communication speed) is outside the scope of control.

Get Setting Value Command

- Setting Value Acquisition
 [Command] RMEM
 [Process] Sends all data related to camera control commands.
 The setup of COMM setting commands is outside the scope of control.
 [Data Transmission]
 The setting value is divided by / (CR/LF) and returned. This is done in the order shown below. Basically, the setting value is the value specified when it is set up by the command.
 However, for gain setup, the last setting command, either GAIN-STEP or GAIN-FINE, is displayed. The setting value is returned according to the following forms.

GAIN-STEP : S##

GAIN-FINE : F###

(### : Specified value when set up by the command)

MODE / SHUTTER / GAIN (GAIN-STEP or GAIN-FINE) / BINNING / PARTIAL / FPS/ RPS/ VHINTTEXT / EXTHVCLK / EXTTRG / TRG-OVLP / TERM /CLKSEL

Other Commands

- Version Display
 [Command] VERSION
 [Process] Displays a model name and a software version.
 The screen display is as follows:

```
<Input>          VERSION<CR>
<Output on screen> CAMERA : V500 or X700
                  <CR/LF>
                  VERSION : #.##<CR/LF>
```

- Help Display
 [Command] HELP
 [Process] Displays the list of available commands.

Command	Parameter 1	Parameter 2	Description
MODE	Operation mode	—	Operation mode setting
SHUTTER	Shutter Setting	—	Shutter speed setting
GAIN-STEP	Gain	—	Gain-Step setting
GAIN-FINE	Gain	—	Gain-Fine adjustment setting
BINNING	Mode	—	Binning mode setting
PARTIAL	Mode	—	High-rate scan setting
FPS	Area	—	PS2 upper high-speed transfer area setting
RPS	Area	—	PS2 lower high-speed transfer area setting
VHINTEXT	IN/OUT	—	VD/HD IN/OUT setting
EXTHVCLK	Input selection	—	External HD/VD/CLK signal input selection
EXTTRG	Input selection	—	External trigger signal input selection
TRG-OVLP	Overlap selection	—	Overlap setting
TERM	Termination	—	75 ohm termination setting
CLKSEL	Clock selection	—	Master clock setting
BRATE	Baud rate	—	Serial communication speed setting
INIT	—	—	Setting initialization
SAVE	—	—	Save settings
LOAD	—	—	Read settings
RMEM	—	—	Setting value acquisition
VERSION	—	—	Version display
HELP	—	—	Help display

Specifications

Specifications

Imaging system

Pickup device	Progressive scan 1/3 type CCD
Effective picture elements (horizontal/vertical)	XCL-X700: 1034 × 779 XCL-V500: 659 × 494
Optical blank	XCL-X700: 43 elements on each horizontal line XCL-V500: 33 elements on each horizontal line
CCD vertical drive frequency	XCL-X700: 23.23 kHz ± 1% (Internal clock) XCL-V500: 31.47 kHz ± 1% (Internal clock)
CCD horizontal drive frequency	XCL-X700: 29.5 MHz (Internal clock) XCL-V500: 24.55 MHz (Internal clock)
Cell size (horizontal/vertical)	XCL-X700: 4.65 × 4.65 μ m XCL-V500: 7.4 × 7.4 μ m
Chip size (horizontal/vertical)	XCL-X700: 5.80 × 4.92 mm XCL-V500: 5.79 × 4.89 mm

Optical system and others

Lens mount	C-mount
Flange focal length	17.526 mm
Synchronization	Internal/external (automatically switched according to input signal)
External sync signal I/O	HD/VD (HD/VD level: 2-5 Vp-p)
External sync allowable frequency	±1% (of horizontal sync frequency)

H Jitter	Less than 20 nsec (Internal clock)
Video output	10 bits LVDS
Reference video output level:	940 steps
Reference pedestal level:	64 steps
White clip:	1023 steps
Output signal frequency	XCL-X700: 29.2 Hz (Internal clock, normal mode) XCL-V500: 59.94 Hz (Internal clock, normal mode)
Effective lines	XCL-X700: 1024 × 768 (horizontal/vertical) XCL-V500: 648 × 494 (horizontal/vertical)
Horizontal resolution	XCL-X700: 800 TV lines XCL-V500: 500 TV lines
Sensitivity	400 lx, F5.6 (0 dB)
Minimum illumination	1 lx (with the gain control at maximum, F1.4)
Gain	0 to +18 dB
γ	1 (fixed)
Read mode	normal/binning
Shutter	External trigger shutter
Shutter speed	External trigger shutter: 1/4 to 1/100000 sec.
Power	+12 V DC (Range: +10.5 to 15 V)
Power consumption	XCL-X700: 2.2 W XCL-V500: 2.0 W
Operating temperature:	-5 to +45°C (23 to 113°F)
Storage temperature:	-30 to +60°C (-22 to 140°F)
Operating relative humidity:	20 to 80% (no condensation)
Storage relative humidity:	20 to 95% (no condensation)
Vibration resistance	10 G (20 Hz to 200 Hz)
Shock resistance	70 G

External dimension (w/h/d)	29 × 29 × 30 mm (1 ³ / ₁₆ × 1 ³ / ₁₆ × 1 ³ / ₁₆ inches)
Mass	55 g (2 oz)
MTBF	73,880 hours (about 8.4 years)
Accessories	Lens mount cap (1) Operating Instructions (1)

Design and specifications are subject to change without notice.

IMPORTANT

The nameplate is located on the bottom.

Spectral Sensitivity Characteristics (Typical Values)

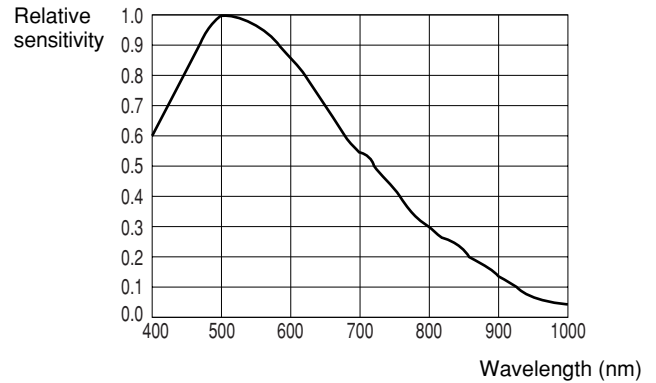

(Lens characteristics included, and light source characteristics excluded.)

XCL-X700 Dimensions

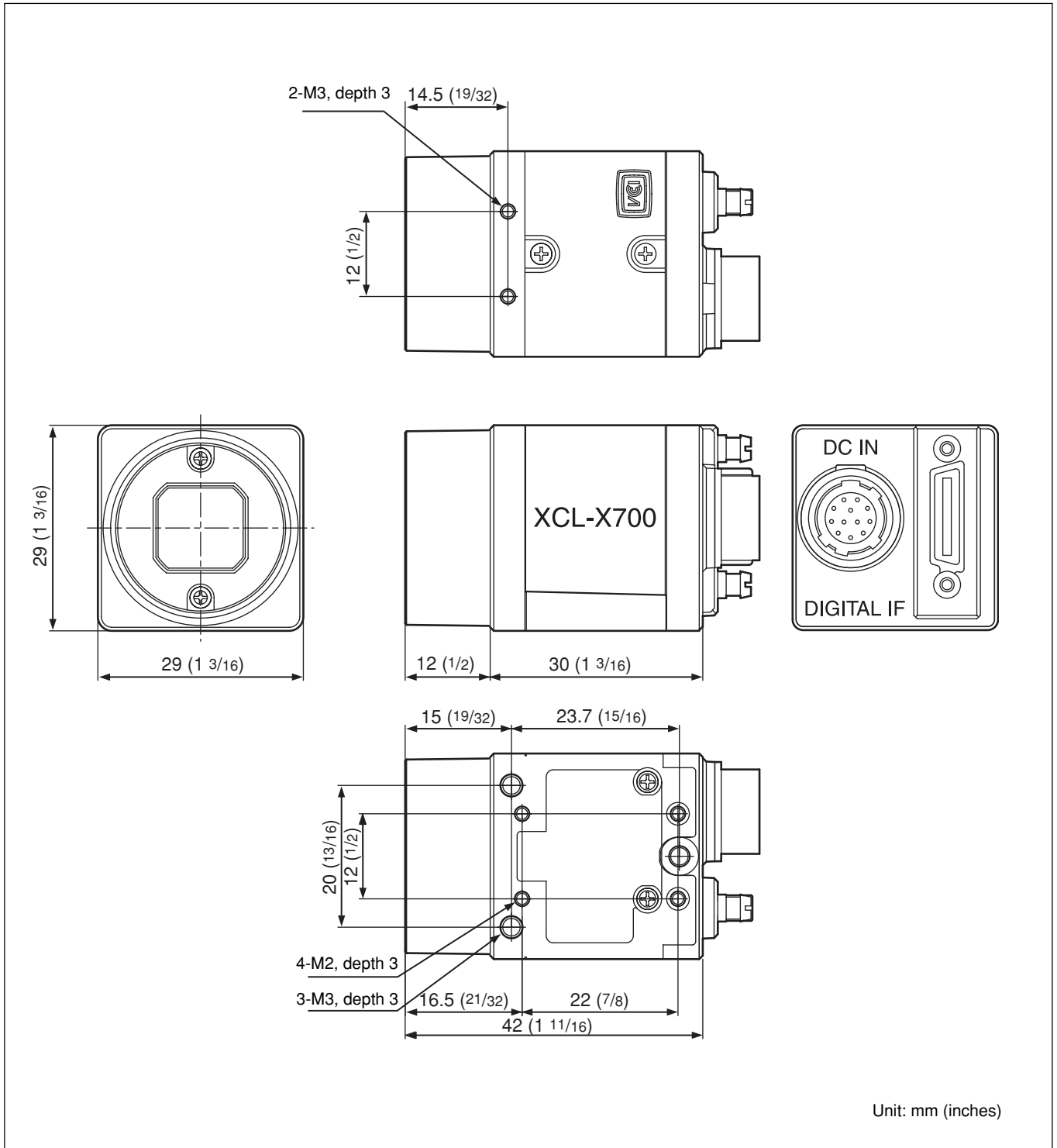

XCL-V500 Dimensions

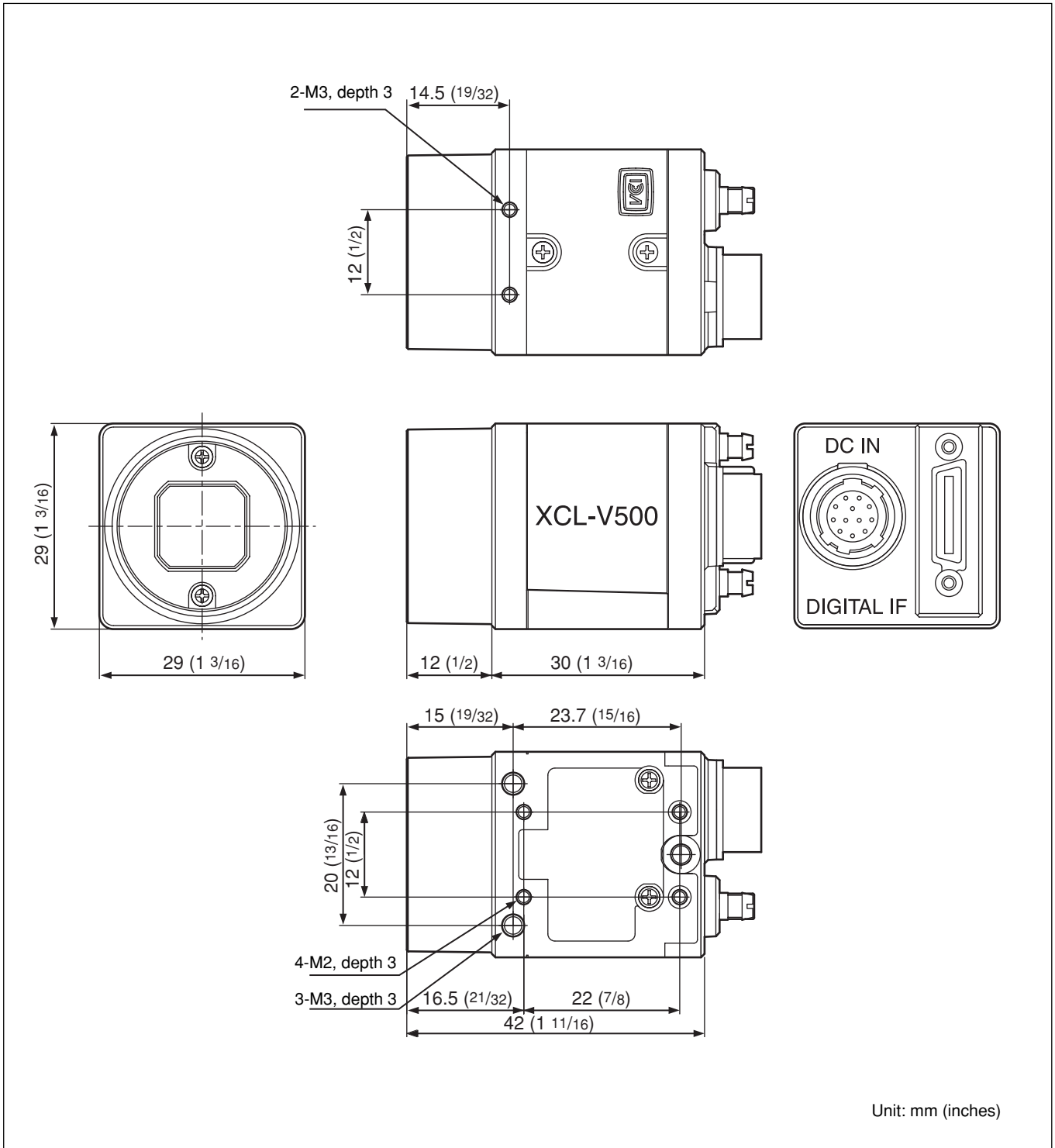

Appendix

Available Accessory Lenses

The following shows the specifications of the available accessory lenses.

List of C-Mount Lens

Model name		VCL-08YM	VCL-12YM	VCL-16Y-M	VCL-25Y-M	VCL-50Y-M
Focal distance (mm) (inches)		8 (¹¹ / ₃₂)	12 (¹ / ₂)	16 (²¹ / ₃₂)	25 (1)	50 (2)
Maximum aperture ratio		1:1.4	1:1.8	1:1.4	1:1.6	1:2.8
Operation	Iris	Manual				
	Focus	Manual				
Field angle (Horizontal × Vertical)	1/2 type CCD	42.6° × 32.6°	29.6° × 22.4°	22.6° × 17.0°	14.6° × 11.0°	7.3° × 5.5°
MOD* (mm) (inches)		207 (8 ¹ / ₄)	208 (8 ¹ / ₄)	289 (11 ¹ / ₂)	204 (8 ¹ / ₈)	438 (17 ¹ / ₄)
Image pickup range during maximum proximity (Horizontal × Vertical) (mm) (inches)		182.9 × 137.2 (7 ¹ / ₄ × 5 ¹ / ₂)	127 × 95 (5 × 3 ³ / ₄)	121 × 91 (4 ⁷ / ₈ × 3 ⁵ / ₈)	52.7 × 39.8 (2 ¹ / ₈ × 1 ⁵ / ₈)	49.8 × 37.3 (2 × 1 ¹ / ₂)
Back focus		11.54 mm (¹⁵ / ₃₂ inches)	10.99 mm (⁷ / ₁₆ inches)	12.50 mm (¹ / ₂ inches)	11.60 mm (¹⁵ / ₃₂ inches)	22.10 mm (⁷ / ₈ inches)
Flange back		17.526 mm (²³ / ₃₂ inches)	17.526 mm (²³ / ₃₂ inches)	17.526 mm (²³ / ₃₂ inches)	17.526 mm (²³ / ₃₂ inches)	17.526 mm (²³ / ₃₂ inches)
Weight		40 g (1 oz)	40 g (1 oz)	50 g (2 oz)	42 g (1 oz)	50 g (2 oz)

* MOD: Minimum Object Distance between the tip of the lens body and the object.

Sony reserves the right to change specifications of the products and discontinue products without notice.

Technical information contained herein is for reference only and does not convey any license by any implication or otherwise under any intellectual property right or other right of Sony or third parties.

Sony cannot assume responsibility for any right infringements arising out of the use of this information.